

Thomson Electrak[®] XD Electric Linear Actuator

Installation Manual

Edition 2026-02



Version history

Edition	Reason for revision
2023-05	First edition
2023-07	Updates and corrections to bus data in sections 5 and 6.
2024-04	Updates and corrections in sections 4, 5 and 6.
2025-02	Position feedback added to option PLS, IP rating clarification note added to 4.3 and 8.1, update of speed commands for COO and CNO bus options
2026-02	Updated front and back cover logotypes and layout.

Warranty

The Thomson Electrak® XD is warranted to be free from defects in materials and workmanship for a period of twelve (12) months from date of delivery. The application of this product is the responsibility of the buyer and Thomson makes no representation or warranty as to the suitability of the product for any particular use or purpose. For a copy of the entire warranty for this product that is contained in our standard terms and conditions of sale, please go to http://www.thomsonlinear.com/website/com/eng/support/terms_and_conditions.php.

Disclaimer

Technical changes to improve the performance of the equipment may be made without prior notice!

All rights reserved. No part of this work may be reproduced in any form (by printing, photocopying, microfilm or any other method) or processed, copied or distributed by electronic means without the written permission of Thomson.

Contents

1. General	4
1.1 About this manual	4
1.2 Target group	4
1.3 Symbols used	4
1.4 Transport and storage	4
1.5 Packaging	4
1.6 Disposal	4
1.7 Support	4
2. Safety	5
2.1 Safety notes	5
3. Standards	5
3.1 EC Declaration of conformity	5
4. Installation	6
4.1 Product label	6
4.2 Terminology	7
4.3 Operation environment	7
4.4 Mechanical installation	8
4.5 Electrical installation	13
4.6 Control options installation and operation	15
5. SAE J1939 CAN bus information	24
5.1 Introduction to CAN bus SAE J1939	24
5.2 CAN bus SAE J1939 communications protocol	24
6. CANopen® information	28
6.1 Introduction to CANopen	28
6.2 Actuator control	29
6.3 Actuator feedback	30
7. Troubleshooting	32
7.1 Troubleshooting	32
8. Technical specifications	33
8.1 Technical data	33
8.2 Duty cycle	34
8.3 Ordering key	35

1. General

1.1 About this manual

This manual contains mechanical and electrical installation instructions for the Thomson Electrak® XD electric linear actuator. It also contains, among other things:

- technical data
- installation data
- type designation key.

It is important to carefully read this manual before installing the actuator and to have the correct qualifications needed to perform the installation.

1.2 Target group

This manual addresses qualified mechanical and electrical personnel.

1.3 Symbols used



This symbol is shown to highlight a general warning, general instruction or as a warning for a mechanical hazard.

1.4 Transport and storage

The actuator may only be transported and stored in the original packaging supplied by Thomson. The temperature during transportation and storage must be between -40 to +85° C (-40 to +185° F). Avoid shocks to the package. If the package is damaged, check the actuator for visible damage and notify the carrier, and if appropriate Thomson as well.

1.5 Packaging

The packaging consists of a cardboard box. The box contains the actuator and this manual. For large quantity orders, bulk packaging may be used, in which case the packaging and the content will vary depending on the order agreement.

1.6 Disposal

Where required by law, used packaging and actuators are taken back by Thomson for professional disposal if the transportation cost is paid by the sender. Please contact Thomson for shipping information.

1.7 Support

If technical support or information is needed for this product, please contact the nearest Thomson Service Center. See the back of this manual. You can also visit www.thomsonlinear.com for information on this product and how to contact us.

2. Safety



2.1 Safety notes





- Only properly qualified personnel are permitted to perform mechanical and electrical installation of this product. Properly qualified personnel are familiar with mechanical or electrical installation work and have the appropriate qualifications for their job.
- Read this manual and any other available documentation before working on the equipment that the actuator is or shall be a part of.
- Conform strictly to the information contained in this manual and on the actuator product label on the actuator. Never exceed the performance limits stated herein.
- Never work on the actuator or its installation with the power on.
- Never unplug any cables or connectors during operation or with power on.
- Immediately stop using the actuator if it seems faulty or damaged in any way and notify an appropriate person so that corrective actions can be taken.
- Never open the actuator as that will compromise the sealing and the function of the actuator. There are no serviceable components inside.
- Grease may be present on the extension tube. Contact is non-hazardous. Film should not be removed.

3. Standards

3.1 EC and UKCA Declaration of incorporation of partly completed machinery





	Declaration of Conformity of partially completed machinery	 <i>Linear Motion. Optimized.</i>
We, the company Tollo Linear AB, Estridsväg 10, SE-291 65 Kristianstad, Sweden		
Hereby in sole responsibility declare the conformity of the product series Electric Linear Actuator Electrak XD (all model types included)		
Manufactured by Thomson Linear LLC, 1300 North State Street, Marengo Illinois 60152, USA		
With the following directive - EC-Directive 2006/42/EC – Machine Directive (MD) Used Harmonized Standard(s): EN ISO 12100:2010 – Safety of Machinery – General Principles for Design - Risk Assessment and Risk Reduction		
And further directive(s) - EC-Directive 2014/30/EU – Electromagnetic Compatibility Directive (EMCD) Used Harmonized Standard(s): EN 12895:2015+A1:2019 – Electromagnetic compatibility (EMC) – Industrial Trucks, emissions replaced with the additional included standard EN 61000-6-4:2018 – Electromagnetic compatibility (EMC) – Generic standards – Emission standard for industrial environments - EC-Directive 2011/65/EU with amendment 2015/863/EU – Restriction of Hazardous Substances in Electrical and Electronic Equipment (RoHS2 & RoHS3) - EC-Directive 2012/19/EU – Waste Electrical and Electronic Equipment (WEEE)		
Year of first Declaration: 2023		
Safety depends upon installing and configuring the linear actuator per the manufacturer's recommendations. The machine in which this product is to be installed must conform to the provisions of the EMC directive 2014/30/EU. The installer is responsible for ensuring that the end product complies with the EMI requirements and all the relevant laws in the country where the equipment is installed.		
Issued by:	Product Line Manager Mr. Håkan Persson Kristianstad, 2023-05-05  Signature	
Responsible person for technical documentation: Mr. Peter Gnebner, Tollo Linear AB, Estridsväg 10, SE-291 65 Kristianstad, Sweden		
Doc. No: 110913		

	Declaration of Conformity of partially completed machinery	 <i>Linear Motion. Optimized.</i>
We, the company Tollo Linear AB, Estridsväg 10, SE-291 65 Kristianstad, Sweden		
Hereby in sole responsibility declare the conformity of the product series Electric Linear Actuator Electrak XD (all model types included)		
Manufactured by Thomson Linear LLC, 1300 North State Street, Marengo Illinois 60152, USA		
With the following directive - S.I. 2008/1597 – Supply of Machinery (Safety) Regulations 2008 Used Harmonized Standard(s): EN ISO 12100:2010 – Safety of Machinery – General Principles for Design - Risk Assessment and Risk Reduction		
And further directive(s) - S.I. 2016/1091 – The Electromagnetic Compatibility Regulations 2016 Used Harmonized Standard(s): EN 12895:2015+A1:2019 – Electromagnetic compatibility (EMC) – Industrial Trucks, emissions replaced with the additional included standard EN 61000-6-4:2018 – Electromagnetic compatibility (EMC) – Generic standards – Emission standard for industrial environments - S.I. 2012/3032 – The Restriction of the Use of Certain Hazardous Substances in Electrical and Electronic Equipment Regulations 2012 - S.I. 2013/3113 – The Waste Electrical and Electronic Equipment Regulations 2013		
Year of first Declaration: 2023		
Safety depends upon installing and configuring the linear actuator per the manufacturer's recommendations. The machine in which this product is to be installed must conform to the provisions of the EMC directive S.I. 2016/1091. The installer is responsible for ensuring that the end product complies with the EMI requirements and all the relevant laws in the country where the equipment is installed.		
Issued by:	Product Line Manager Mr. Håkan Persson Kristianstad, 2023-05-05  Signature	
Responsible person for technical documentation: Mr. Peter Gnebner, Tollo Linear AB, Estridsväg 10, SE-291 65 Kristianstad, Sweden		
Doc. No: 110813		

4. Installation

4.1 Product label

The product label can be found on the side of the cover tube. It will tell you which model of actuator you have, its basic performance data and where it is manufactured. Please study the product label to determine actuator type before starting any installation or service on the actuator. If you need any assistance from Thomson, please provide the serial number, manufacturing date and the designation of the actuator(s) in question. You can also use the QR code on the label to directly access Electrak XD information on www.thomsonlinear.com.

				
1300 North State, Marengo, IL 60152, USA WWW.THOMSONLINEAR.COM				
Model No. XD24B250 - 0300COORMMSM	Mfg. Date 2022 - 02 - 22	Input Voltage 24 VDC	Max Current 28 Amps	
Serial No. X0XX0000X	Max Load 25000 N	Stroke 300mm	Protection Class IP67/IP69k	
 Follow all instructions in the manual. Do not disassemble, no serviceable parts inside. Install fuse between power supply and actuator				
				

4.2 Terminology

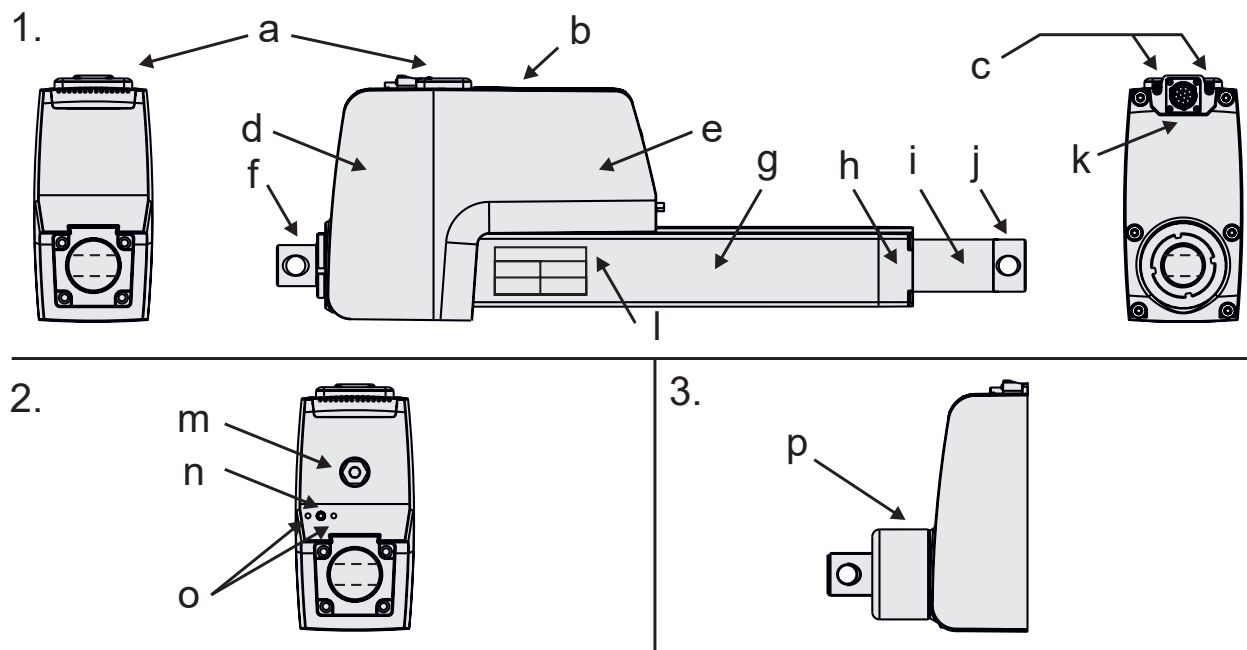

1. Standard features

- a. power terminals cover plate
- b. heat sink
- c. power supply wire inlets
- d. rear housing
- e. motor housing
- f. rear adapter
- g. cover tube
- h. front housing
- i. extension tube
- j. front adapter
- k. control signal connector
- l. product label

Optional Features

2. Manual brake release and override

- m. manual override input
- n. brake release lever
- o. mounting holes for remote brake release bracket

3. Shock load dampener

- p. shock load dampener

4.3 Operation environment



Min. -40° C (-40° F)



Max. +85° C (+185° F)



IP67 / IP69K

1. Operation temperature range is -40 to +85° Celsius (-40 to +185° Fahrenheit).
2. Protection degree against the ingress of water and particles is IP67 / IP69K.
3. Relative humidity range is 10 - 90 % non-condensing.



The protection class is valid only with a mating connector attached to the control signal connector in the actuator housing.

4.4 Mechanical installation

4.4.1 General installation safety notes



- Never work on the actuator with the power switched on.
- Do not hold the extension tube while the unit is energized.
- Failure modes of the actuator should be considered to ensure it does not create harm.

4.4.2 Basic installation considerations

1. Only mount the actuator using the holes in the rear and front adapters. Check the model number on the actuator product label (section 4.1) and then look at the ordering key (section 8.3) to find out your adapter type configuration. See the dimensions table and drawing (section 4.4.3) to find out the exact actuator and adapter dimensions.
2. Make sure that the actuator mounting position allows access to the power terminals cover plate and the control signal connector (section 4.4.5).
3. The power wires enter the rear housing through the power supply wire inlets while the control signals are connected by a cable to the actuator by using the control signal connector.
4. If the actuator is equipped with the optional manual brake release and override input, the lever and the input used to operate these must have enough free space around them to allow access (section 4.4.6).
5. Do not remove the grooved heat sink on top of the actuator.

4.4.3 Dimensions

Rear and Front Adapter Dimensions [mm (in)]					
	Rear Adapter Types				
	M	N	H	K	M + dampening option
B1	16.1 (0.63)	16.1 (0.63)	38.0 (1.50)	16.1 (0.63)	16.1 (0.63)
B2	25.3 (1.00)	29.9 (1.18)	8.2 (0.32)	43.3 (1.70)	68.9 (2.71)
B3	35.0 (1.38)	35.0 (1.38)	M20 × 1.5	35.0 (1.38)	35.0 (1.38)
B4	16.2 (0.64)	16.2 (0.64)	M20 × 1.5	16.2 (0.64)	16.2 (0.64)
B5	-	12.2 (0.48)	-	--	
	Front Adapter Types				
	M	N	P	H	
C1	27.1 (1.07)	35.1 (1.38)	28.1 (1.11)	22.1 (0.87)	
C2	14.9 (0.59)	16.9 (0.67)	35.0 (1.38)	38.0 (1.50)	
C3	44.5 (1.75)	44.5 (1.75)	44.5 (1.75)	44.5 (1.75)	
C4	16.2 (0.64)	16.2 (0.64)	M20 × 1.5	M20 × 1.5	
C5	-	12.2 (0.48)	32.0 (1.26)	-	
C6	-	-	35.0 (1.38)	-	

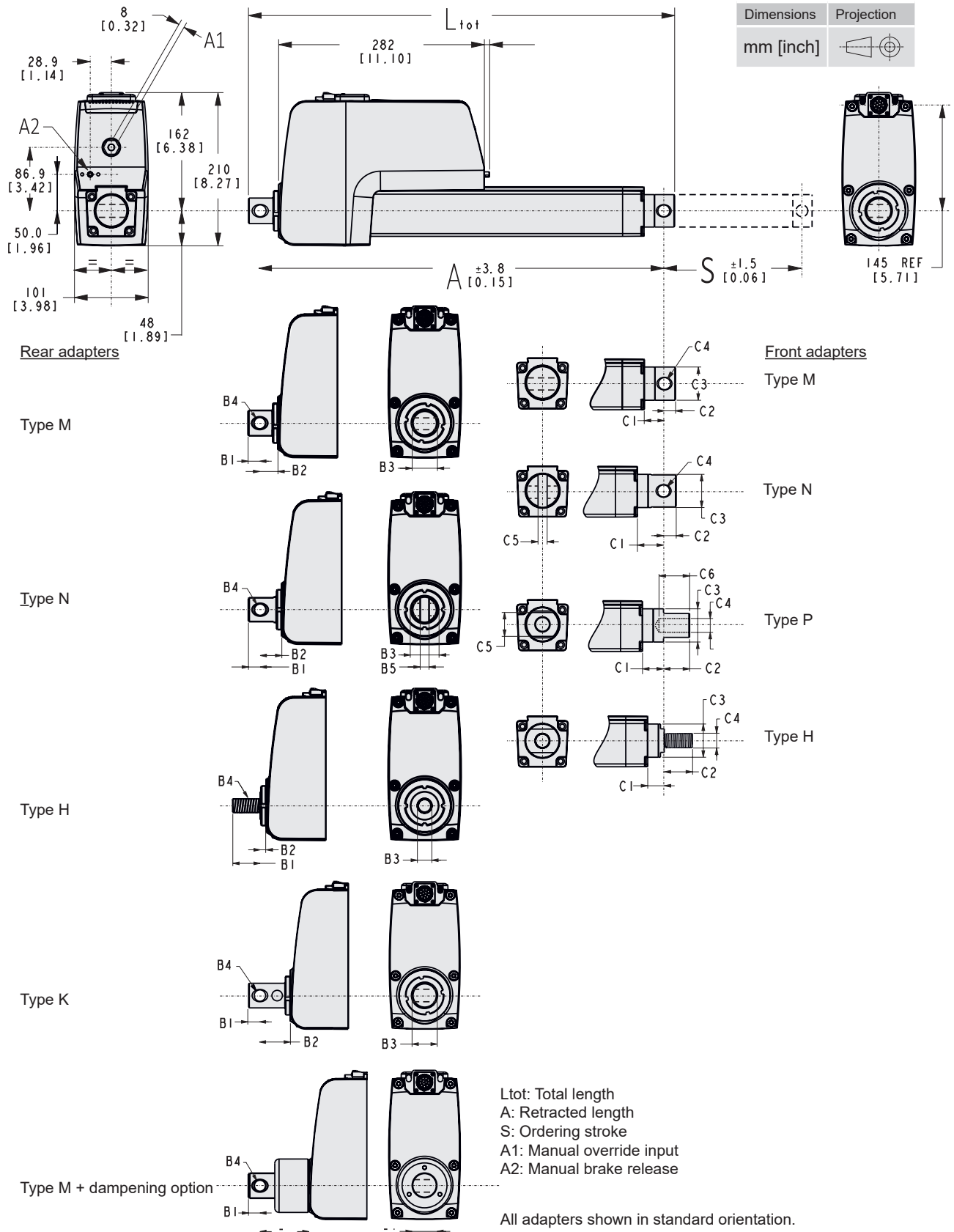

4.4.4 Mounting orientation and forces

1. The actuator can be mounted in any orientation and handle both pushing and pulling loads.
2. Always install actuator so that the force of the load acts in the center of the extension tube and the rear adapter.
3. Only mount the actuator to the rear and front adapter mounting holes.
4. Only use solid mounting pins and support them at both ends.
5. The mounting pins must be parallel to each other both radially and axially.

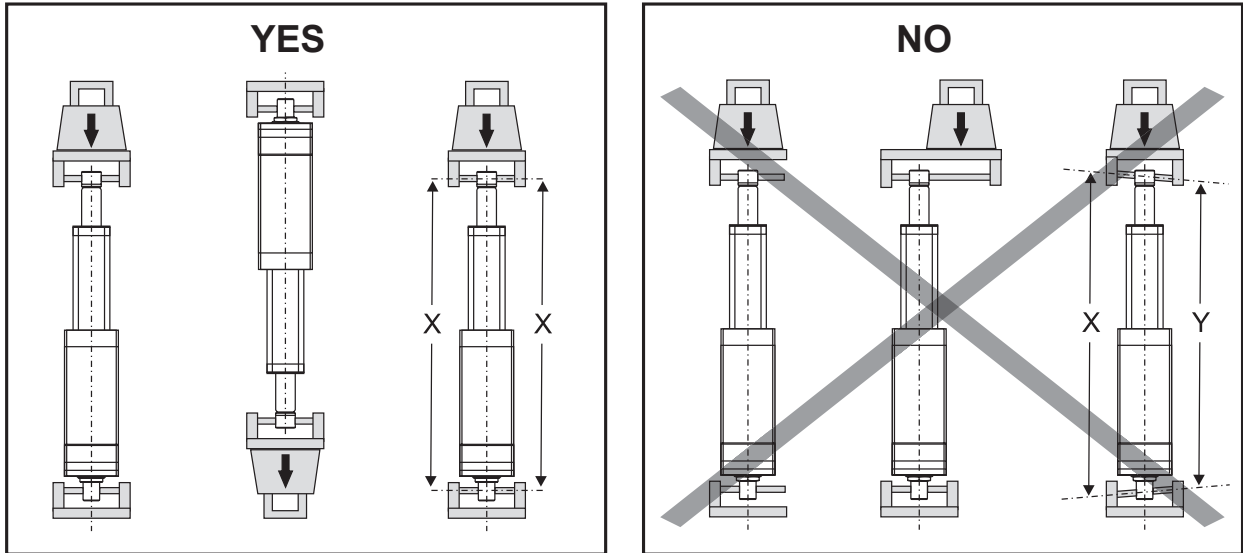

4.4.5 Electrical connections

The actuator is connected to the power supply by two wires to the power terminal studs situated under the power terminal cover plate (a), while the control signals are connected to the control signal connector (b) (section 4.5.3).



4.4.6 General manual brake release and manual override notes - optional features

Make sure when mounting the actuator that there is space enough between the front of the motor and any object to allow both the manual brake (a) release and the override (b) controls to be operated. See drawing below for their positions and dimensions.

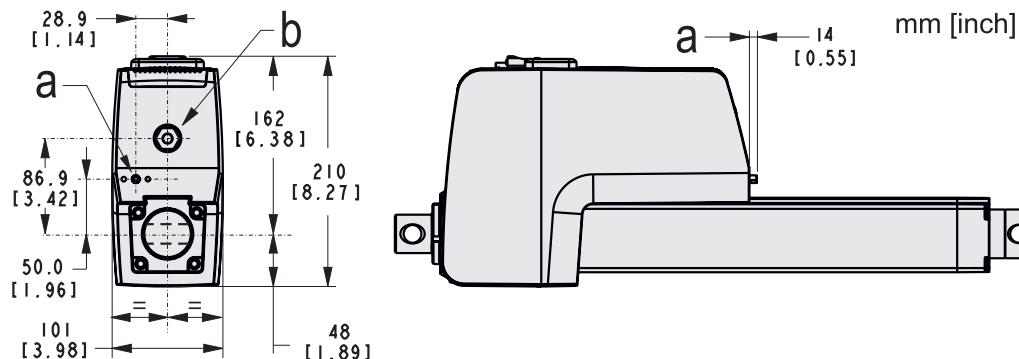

- Always make sure to switch off the power to the actuator before using the manual brake release or manual override.
- Never use the manual brake release and the manual override at the same time.
- Carefully read all operation instructions before using the manual brake release or manual override (section 4.4.7 and/or 4.4.8).

4.4.7 Manual brake release operation - optional feature

The manual brake release allows the holding brake to be manually disengaged from the extension tube so that it can be moved by gravitational force or by pushing or pulling it.

1. The manual release lever (a) can be pulled to open the holding brake and allow the extension tube to be disconnected from the holding brake.
2. If there is a helping load acting on the load/extension tube, it might start to move (backdrive) directly upon release in the direction of the helping load. Only the friction from internal components and the assembly will hinder the extension tube/load to backdrive.
3. The force to release the brake is 67 N (15 lbs), with a stroke of 10 mm (0.4 inch). Lower forces will open the brake partially and allow slower, more controlled movement. The lever has an inside threaded hole (10-32") that can be used to attach a cable/linkage for controlling it remotely.
4. The two M5 mounting holes (b) can be used to install a customer provided bracket in case a cable/linkage assembly is used for remote operation of the lever.

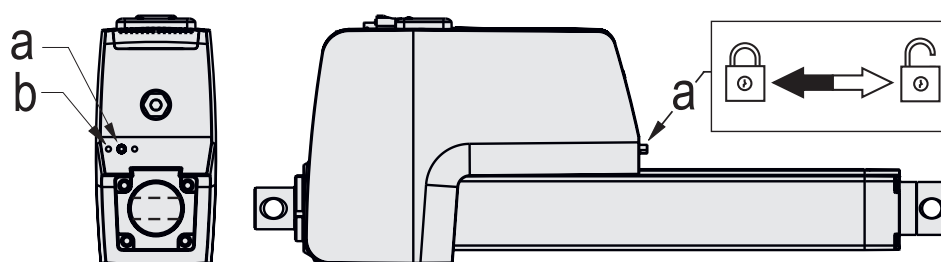

- In the case of a helping load, the operator must ensure releasing the actuator will not create a hazardous situation due to backdriving.
- The backdriving speed of the actuator may be higher than the rated speed of the actuator.
- To limit the maximum speed of the actuator with a helping load, the actuator must be coupled to a power source capable of current regeneration (i.e. batteries or a bidirectional power supply). In the case of an actuator release at full load, the regeneration current will vary depending on the battery size or the regeneration capacity of the power supply.
- Make sure to let the lever fully return to its innermost position before resuming operation.

4.4.8 Manual override operation - optional feature

The manual override allows the extension tube to be moved at power off by manually cranking it in the desired direction using the manual override input.

1. To operate the manual override, remove the cover plug (a) using a 8 mm hex bit. Then turn on the manual override input hexagon (b) using an 8 mm hex bit (c).
2. To extend the actuator, the override hub must be rotated clockwise (c).
3. The maximum torque required to move the extension tube at the fully rated actuator load using the manual override is typically 6 Nm (51 in-lbs).
4. The distance the extension tube travels per manual override input revolution depends on the actuator type. See the table below.

Extension Tube Movement / Manual Override Input Revolution [mm (in)]	
Actuator type	Movement
XDxx-B055	1.3 (0.051)
XDxx-B080	1.3 (0.051)
XDxx-B160	0.5 (0.200)
XDxx-B200	0.3 (0.012)
XDxx-B250	0.3 (0.012)



- Do not apply higher torque than 9 Nm (80 in-lbs) to the manual override input.
- In case that torque is exceeded, a mechanical fuse will break and render the manual override inoperable to protect the actuator. The fuse can only be replaced at the factory.
- Never run the extension tube into the end of stroke as that may damage the actuator.
- If a power tool is used to operate the manual override, its speed should not exceed 500 rpm, and it should start and stop smoothly.
- The override has a maximum run time of 1 minute and requires a 5 minute cool-down between events.

4.4.9 Shock load dampener - optional feature

The shock load dampener will absorb shock loads subjected to the actuator along the extension tube axis. When doing so the actuator adapters will move up to ± 3 mm (0.12 in) from their original position as the dampening elements in the dampener (a) compress or extends, which the mounting assembly must allow for.

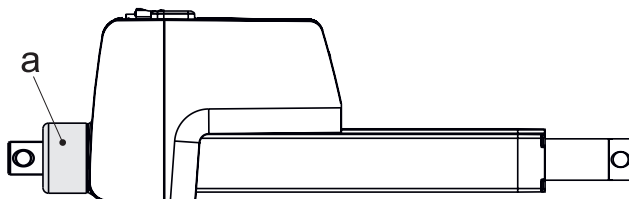

- Do not attempt to open, no serviceable parts inside.

4.5 Electrical installation

4.5.1 General notes



- Make sure the leads/cables leading to the motor can handle the maximum motor current.
- An emergency stop is recommended to reduce the chance of a crushing hazard.
- Never work on the actuator or the wiring with the power switched on.

4.5.2 Fuse

Use a slow blow fuse on the supply voltage input wiring to protect the actuator and the wiring. Size it in accordance with local regulations and the current draw for the application in question.

4.5.3 Electrical connections

The actuator needs to be connected to a power supply and to the control system as described below.

Connection of power supply

The power leads are brought in to the actuator using the power wire inlets and are connected using the M6 sized ring terminal studs accessed by removing the power terminal cover plate. The power terminal cover plate is held in place by two screws (2 × M3 × 8, T10 Torx). The length of the ring clips may not be longer than 34.5 mm (Amax). Do not exceed 4 Nm (35 in-lbs) when torquing the lock nuts on the power studs. Never run the actuator with the cover plate removed.

Connection of control signals

The control signals are connected to the signal connector using a mating connector and are secured to each other with a ring screw. Make sure to tighten the ring screw properly to ensure proper function and sealing. Exactly how to connect the control signals depends on which type of control your actuator is equipped with and how you choose to use it (section 4.6.12 to 4.6.17).

Mating connector data

Amphenol Ecomate connector with normal backshell: RTS6BS14N12P03, 12 pin

Amphenol Ecomate connector with short backshell: RTS6BS14N12PHEC03, 12 pin

Amphenol Ecomate pin terminal: SP24M2F which is for 24 - 26 AWG / 0.14 - 0.25 mm² leads (part number depends on the wire gauge / cross section of the leads being used).

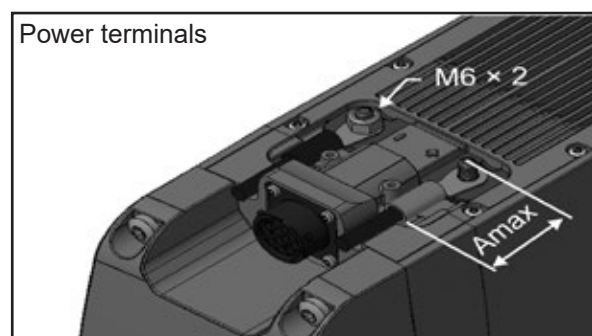

4.5.4 Power supply lead cross section

To avoid malfunction due to voltage drop, the cross section of the leads between the actuator power terminals and the power source must be of sufficient size in order to prevent the supply voltage to drop to levels below the supply voltage limit of the actuator. Calculations to determine the necessary cross section should take local regulations, application specifics and the actuator supply voltage limits into account.

4.5.5 Power supply requirements

The power supply used to power the actuator must fulfill the following requirements.

1. The power supply must be sized so that it can handle both the average power over the duty cycle, as well as the peak current and the inrush current (section 4.5.6).
2. The power supply must be able to handle the energy that the motor regenerates.
3. At low temperatures down to $-40\text{ }^{\circ}\text{C}$ ($-40\text{ }^{\circ}\text{F}$), the power required can be up to two times higher than normal.



When the motor decelerates, brakes or is being rotated when using the manual brake release, it will work as a generator and send energy back to the battery/power supply. Under a helping load condition this energy can correspond to up to 60% of the nominal power rating for the actuator in question. The battery/power supply and the rest of the system must be able to handle this regenerated energy.

4.5.6 Inrush current

At the start of the actuator motion, there is an inrush current that can be up to $3 \times$ the rated current that can last for up to 500 ms.



If using an AC-powered power supply, it must be sized to handle the inrush current (batteries typically have no problem delivering the inrush current). Also contacts, switches and relays must be sized appropriately to be able to handle the inrush current.

4.6 Control options installation and operation

4.6.1 General notes



- Avoid placing signal cables along power cables to reduce the risk of interference.
- Avoid using a vehicle earth as the return conductor. Instead use a two wire system to reduce the risk of interference.
- In very sensitive applications or where there is a risk of interference we recommend using shielded signal cables.
- Keep in mind that long cables in combination with small lead cross sections and low voltages may lead to undervoltage and malfunction due to voltage drop.
- Relays or other coil operated devices should have spark protection to avoid interference.
- Never work on the actuator or the wiring with the power switched on!

4.6.2 Speed control by adjusting the input voltage



Electrak XD cannot be speed controlled by adjusting the input voltage. When using battery or full wave rectified direct currents that are within the acceptable voltage limits, the built-in Electronic Monitoring Package will keep the actuator at the correct speed. Outside of the limits, the actuator will be stopped (also see section 4.6.3). When attempting to use Pulse Width Modulation (PWM) to speed control the actuator, the internal PCB will be permanently damaged and cause malfunction.

4.6.3 Electrak Monitoring Package

All controls are equipped with the Electrak Monitoring Package which includes the following features and functions.

Electrak Monitoring Package		
Feature	Functions	Reset
Speed monitoring	The unit keeps the speed constant.	-
Current monitoring	Shuts down the actuator on overload.	Non Can bus units: if units stops when extending, reset is done by activating the retract input and vice versa. Can bus units: reset is done by disabling the enable bit.
Voltage monitoring	Stops motion when the supply voltage are outside the normal ranges.	When voltage returns to the normal range the actuator can be run again. If the conditions for actuator movement are met when the voltage returns to normal range the actuator immediately will start to move.
Temperature monitoring	Stops motion when the temperature are outside the normal ranges.	When temperature returns to the normal range the actuator can be run again. If the conditions for actuator movement are met when the voltage returns to normal range the actuator immediately will start to move.
Temperature compensation	Enables operation at low temperatures by increasing the max. allowed current limit by up to 2.25 × the normal limit.	-
Software controlled end-of-stroke limits	Protect the actuator and ensure smooth stops.	-
Dynamic braking	Produces quick, repeatable stops with no coasting.	-

4.6.4 How to determine the control option

Electrak XD is equipped with one of the control options in the table below. To determine the option your actuator has, check the model number on the product label on the actuator (section 4.1) and then check the ordering key (section 8.3). Use the table below and go to the corresponding sections for further information.

Control Options		
Option	Functions	Section
LXX	Electrak Monitoring Package	4.6.3
	Extend and retract inputs	4.6.5
	Speed control input	4.6.6
	Force feedback function	4.6.7
	Wiring diagram	4.6.12
LLX	Electrak Monitoring Package	4.6.3
	Extend and retract inputs	4.6.5
	Speed control input	4.6.6
	Force feedback function	4.6.7
	End-of-stroke indication outputs	4.6.9
	Wiring diagram	4.6.13
LXP	Electrak Monitoring Package	4.6.3
	Extend and retract inputs	4.6.5
	Speed control input	4.6.6
	Force feedback function	4.6.7
	Position feedback output	4.6.10
	Wiring diagram	4.6.14
LLP	Electrak Monitoring Package	4.6.3
	Extend and retract inputs	4.6.5
	Speed control input	4.6.6
	Force feedback function	4.6.7
	End-of-stroke indication outputs	4.6.9
	Position feedback	4.6.10
	Wiring diagram	4.6.15
PLS	Electrak Monitoring Package	4.6.3
	Extend and retract inputs	4.6.5
	Speed control input	4.6.6
	Force feedback function	4.6.7
	Position feedback	4.6.10
	Programmable end-of-stroke software limits	4.6.11
	Wiring diagram	4.6.16
CNO	Electrak Monitoring Package	4.6.3
	Force feedback function for options CNO/COO	4.6.6
	SAE J1939 CAN bus information	5
	Wiring diagram	4.6.17
COO	Electrak Monitoring Package	4.6.3
	Force feedback function for options CNO/COO	4.6.6
	CANopen® information	6
	Wiring diagram	4.6.17

4.6.5 Extend and retract inputs

The extend and retract inputs let you control the direction of the extension tube motion using low-level voltage signals to switch the motor. If both signals are inactive or active at the same time, the actuator will remain still or stop. For wiring, see the wiring diagram for your control option (also see section 4.6.3).

Low-level signal motor switching data		
Extend / retract input voltage	[Vdc]	9 - 64
Extend / retract input current	[mA]	0.35 - 2.75

4.6.6 Speed control input (not applicable for units with option CNO/COO)

If the speed control input is not used when the extend and retract inputs are active, the actuator will move at its full speed as long as the max. load is not exceeded. If a 0 - 5 Vdc signal is connected to the speed control input, the speed of the actuator can be regulated between 20 - 100% of its full speed where 0 - 0.5 V corresponds to full speed and 1 - 5 V corresponds to 20% of full speed up to full speed. For wiring, see the wiring diagram for your control option (also see section 4.6.3).

Low-level Signal Motor Switching Technical Data		
Speed control input voltage range	[Vdc]	0.5 - 5
Speed control range of full speed	[%]	20 - 100

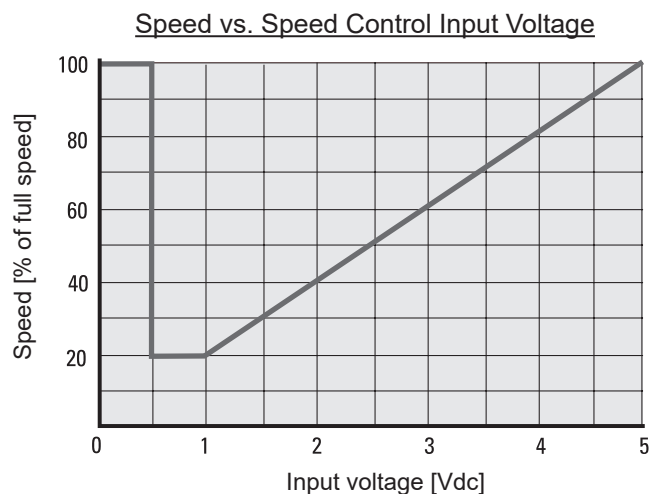

4.6.7 Force feedback function (not applicable for units with option CNO/COO)

In order to use the force feedback output, the actuator must be equipped with an integral force feedback sensor (rear adapter type K). The force output is a 0 - 5 Vdc signal where 2.5 V is zero force, 0.5 V is 25 kN compression force and 4.5 V is 25 kN tension force. Between 0.5 - 4.5 V, the output changes 1 mV per 12.5 N in change of force. For wiring, see the wiring diagram for your control option (also see section 4.6.3).

Force Feedback Technical Data		
Force feedback output voltage range	[Vdc]	0.5 - 4.5
Force feedback linearity	[%]	± 5
Force feedback resolution	[N/mV]	12.5

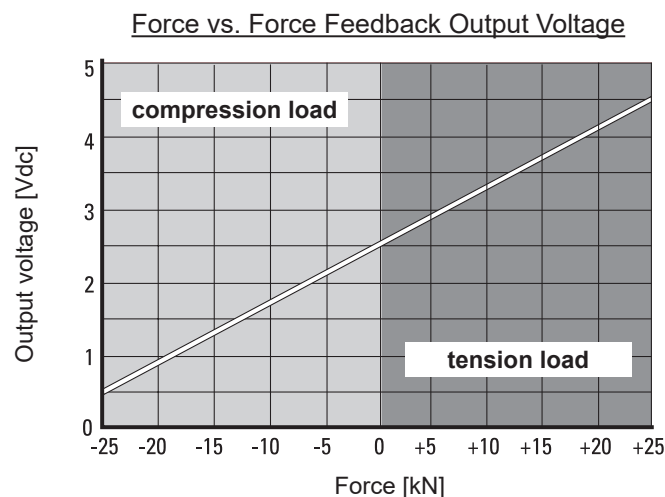

4.6.8 Force feedback function for options CNO/COO

In order to use the force feedback function, the actuator must be equipped with an integral force feedback sensor (rear adapter type K). The force is then sent over the bus according to the message structure for the type of bus being used. For SAE J1939 CAN bus (option CNO), see section 5 and for CANopen® (option COO), see section 6. For wiring, see the wiring diagram in section 4.6.17.

4.6.9 End-of-stroke indication outputs (not applicable for units with option CNO/COO)

When the extension tube is in its fully extended or retracted position, a contact closes to indicate this position. There is one contact for fully extended and one for fully retracted. For wiring, see the wiring diagram for your control option (also see section 4.6.3).

End-of-Stroke Indication Outputs Technical Data		
End-of-stroke output contact type		potential free
Max. end-of-stroke output voltage	[Vdc/Vac]	30/120
Max. end-of-stroke output current	[mA]	100

4.6.10 Position feedback output (not applicable for units with option CNO/COO)

The position feedback output indicates the position of the extension tube by changing its voltage between 0.5 - 4.5 Vdc. The resolution of the signal depends on the ordering stroke of the actuator. For wiring, see the wiring diagram for your control option (also see section 4.6.3).

Position Feedback Output Technical Data		
Position feedback output signal voltage range	[Vdc]	0.5 - 4.5
Position feedback output signal linearity	[%]	± 0.25
Position feedback output signal resolution	[mm/mV]	ordering stroke length (S) [mm] / 4

4.6.11 Programmable end-of-stroke software limits (not applicable for units with option CNO/COO)

This function allows you to program the actuator to stop extending and retracting at any position along the stroke of the extension tube. The programming is done by driving the extension tube to the desired positions and program them using the programming input on pin E and common on pin D in the connector as in the steps described below. For wiring, see the wiring diagram for your control option (also see section 4.6.3).

Programming of the software limit positions:

1. Drive the extension tube to the position you want the extension tube to stop at using the extend and retract inputs (also see section 4.6.16).
2. Power off the unit.
3. Connect the set limits input (pin E) to common (pin D).
4. Activate the extend or retract input depending on which direction you want the motion to stop the unit. Activating both inputs will clear any programmed software limit switches.
5. Power on the unit to complete the programming.

4.6.12 Control option LXX wiring diagram

Control Option LXX Features	
Electrak Monitoring package	section 4.6.4
Extend / retract inputs	section 4.6.5
Speed control input	section 4.6.6
Force feedback function	section 4.6.7

Input Voltage and Current Draw	
Supply voltage limits	[Vdc]
XD24	18 - 32
XD48	36 - 60
Current draw @ min. / max. load	[A]
XD24-Bxxx	6 / 28
XD48-Bxxx	3 / 14

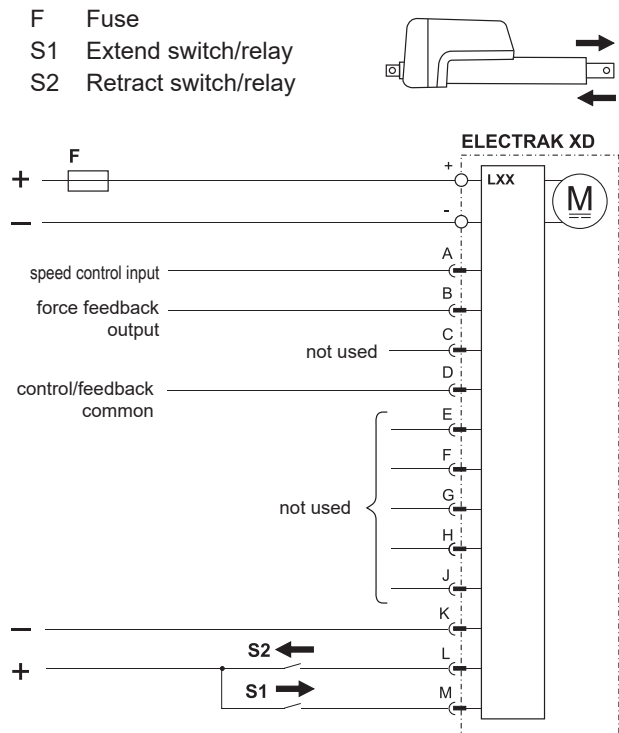

4.6.13 Control option LLX wiring diagram

Control Option LLX Features	
Electrak Monitoring package	section 4.6.4
Extend / retract inputs	section 4.6.5
Speed control input	section 4.6.6
Force feedback function	section 4.6.7
End-of-stroke indication outputs	section 4.6.9

Input Voltage and Current Draw	
Supply voltage limits	[Vdc]
XD24	18 - 32
XD48	36 - 60
Current draw @ min. / max. load	[A]
XD24-Bxxx	6 / 28
XD48-Bxxx	3 / 14

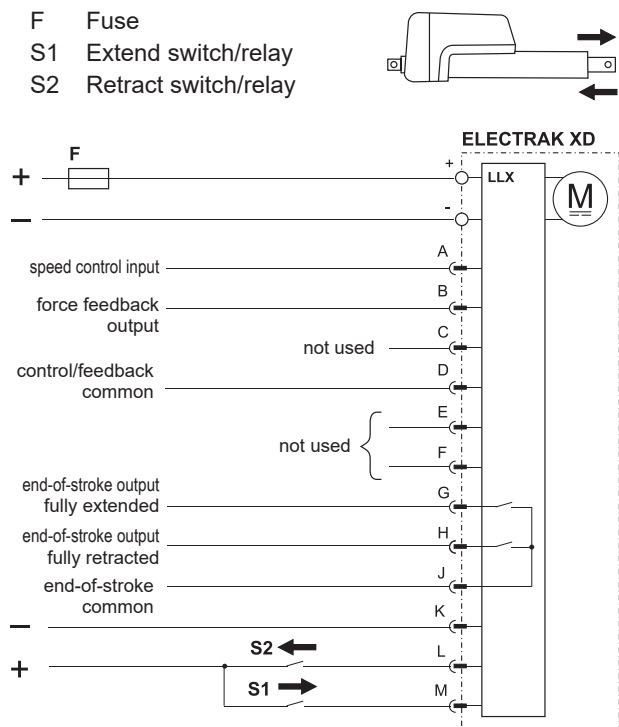

4.6.14 Control option LXP wiring diagram

Control Option LXP Features	
Electrak Monitoring package	section 4.6.4
Extend / retract inputs	section 4.6.5
Speed control input	section 4.6.6
Force feedback function	section 4.6.7
Position feedback output	section 4.6.10

Input Voltage and Current Draw		
Supply voltage limits	[Vdc]	
XD24		18 - 32
XD48		36 - 60
Current draw @ min. / max. load	[A]	
XD24-Bxxx		6 / 28
XD48-Bxxx		3 / 14

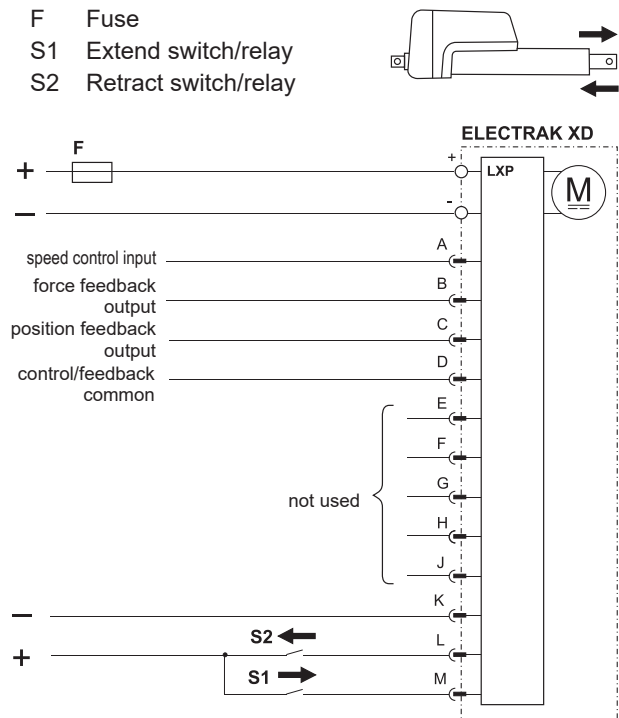

4.6.15 Control option LLP wiring diagram

Control Option LLP Features	
Electrak Monitoring package	section 4.6.4
Extend / retract inputs	section 4.6.5
Speed control input	section 4.6.6
Force feedback function	section 4.6.7
End-of-stroke indication outputs	section 4.6.9
Position feedback output	section 4.6.10

Input Voltage and Current Draw		
Supply voltage limits	[Vdc]	
XD24		18 - 32
XD48		36 - 60
Current draw @ min. / max. load	[A]	
XD24-Bxxx		6 / 28
XD48-Bxxx		3 / 14

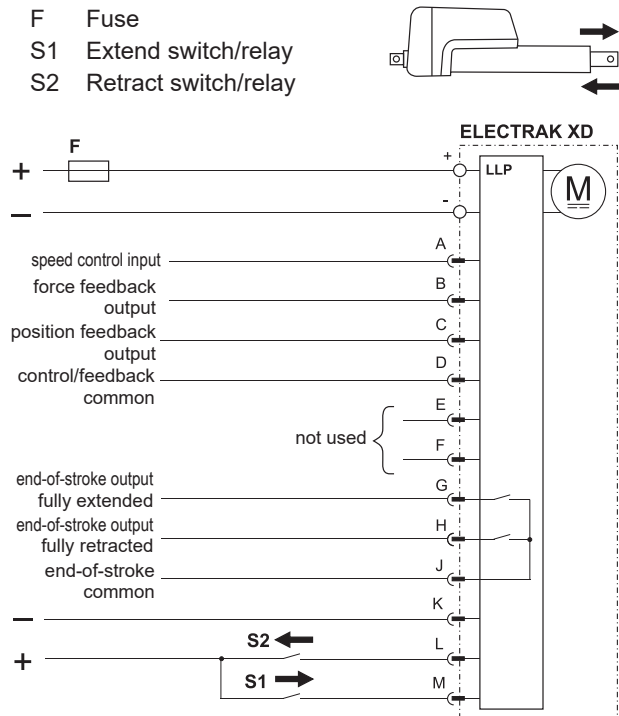

4.6.16 Control option PLS wiring diagram

Control Option PLS Features	
Electrak Monitoring package	section 4.6.4
Extend / retract inputs	section 4.6.5
Speed control input	section 4.6.6
Force feedback function	section 4.6.7
Position feedback output	section 4.6.10
Programmable end-of-stroke software limits	section 4.6.11

Input Voltage and Current Draw		
Supply voltage limits	[Vdc]	
XD24		18 - 32
XD48		36 - 60
Current draw @ min. / max. load	[A]	
XD24-Bxxx		6 / 28
XD48-Bxxx		3 / 14

Programming of the software limit positions:

1. Move the extension tube to the position you want the extension tube to stop at.
2. Power off the unit.
3. Connect the set limits input (pin E) to common (pin D).
4. Activate the extend or retract input depending on in which direction you want the motion to stop the unit at. Activating both inputs will clear any programmed software limit switches.
5. Power on the unit to complete the programming.

- F Fuse
- S1 Extend switch/relay
- S2 Retract switch/relay
- S3 Set programmable software limits switch

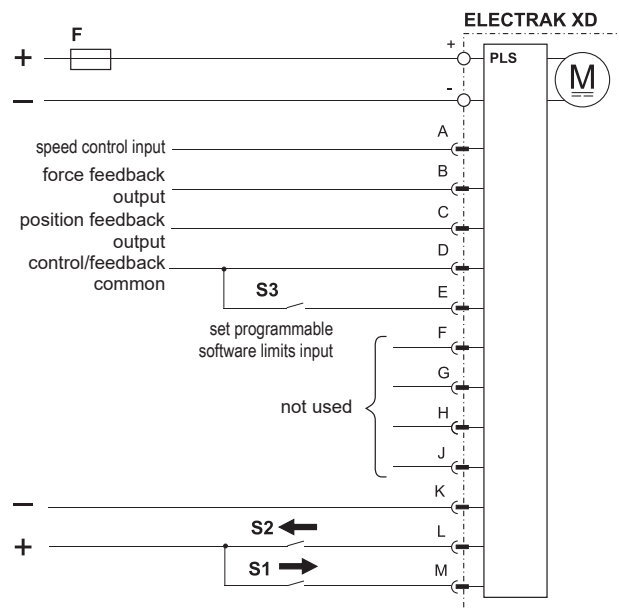
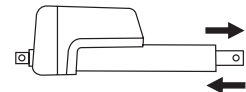

4.6.17 Control options CNO and COO



This document assumes the user is familiar with the SAE J1939 and CANopen standards. Terminology from the standard is used, but not described in detail. See sections 5 and 6 for information on J1939 and CANopen® operation and communication protocols, respectively.

4.6.17.1 General installation data

All motion and protection on the CAN bus option is handled through the CAN messages, including overload protection. Please see sections 5 and 6 for more details on the messages. The CAN high and CAN low wires must also be correctly terminated with termination resistors (section 4.6.17.3). Inputs on pins G, H and J can be used as a binary coded decimal (BCD) adder to change the default address of the actuator. This option can be used when multiple CAN bus actuators are located on a single bus. When using the address inputs, pin K must be connected to supply voltage negative.

Control Option Type CNO and COO	
Command data includes: <ul style="list-style-type: none"> • position • speed • current 	
Feedback data includes: <ul style="list-style-type: none"> • position • speed • current • force (the actuator must also be equipped with the force feedback rear adapter type K) • other diagnostic information 	
Manual extend / retract and address select input voltage [Vdc]	9 - 64
Manual extend / retract and address select input current [mA]	0.35 - 2.75

Input Voltage and Current Draw	
Supply voltage limits [Vdc]	
XD24	18 - 32
XD48	36 - 60
Current draw @ min. / max. load [A]	
XD24-Bxxx	6 / 28
XD48-Bxxx	3 / 14

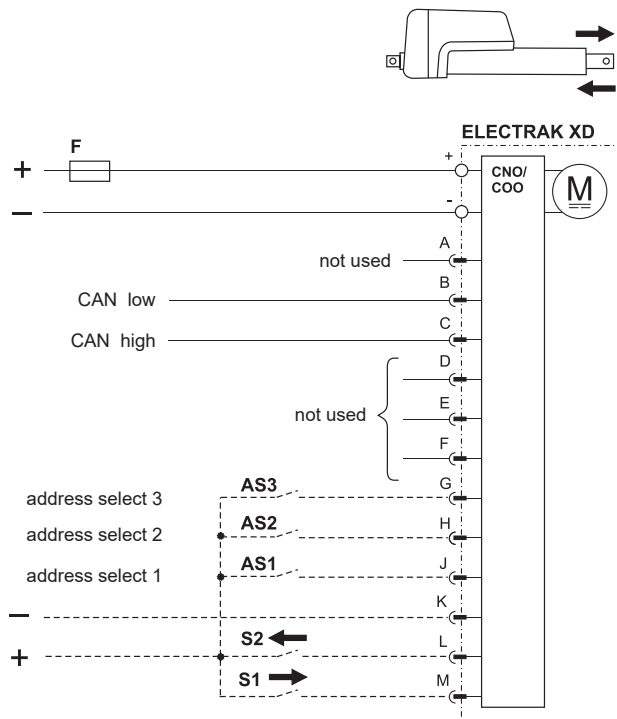

- + / - Supply voltage positive / negative
- F Fuse
- S1 Manual extend switch/relay (optional)
- S2 Manual retract switch/relay (optional)
- AS1 Address selection switch for binary position 1
- AS2 Address selection switch for binary position 2
- AS3 Address selection switch for binary position 3

4.6.17.2 Manual control

The actuator can be manually forced to extend or retract by using the inputs on pins M and L in the connector. When the manual control inputs are used, CAN bus control messages are ignored, but the unit will still provide CAN bus feedback messages. When the inputs are left floating, CAN bus functionality for control messages is restored. When using the manual control extend and retract inputs, pin K must be connected to supply voltage negative.

4.6.17.3 CANopen and SAE J1939 CAN bus installation data

Follow wiring guidelines per ISO-11898 Standard CAN 2.0B. Proper termination resistors (120 Ohm) should be placed between the CAN high and CAN low wires in each end of the of the network, see below. Please refer to section 5 for SAE J1939 communication details, and section 6 for CANopen communication details.

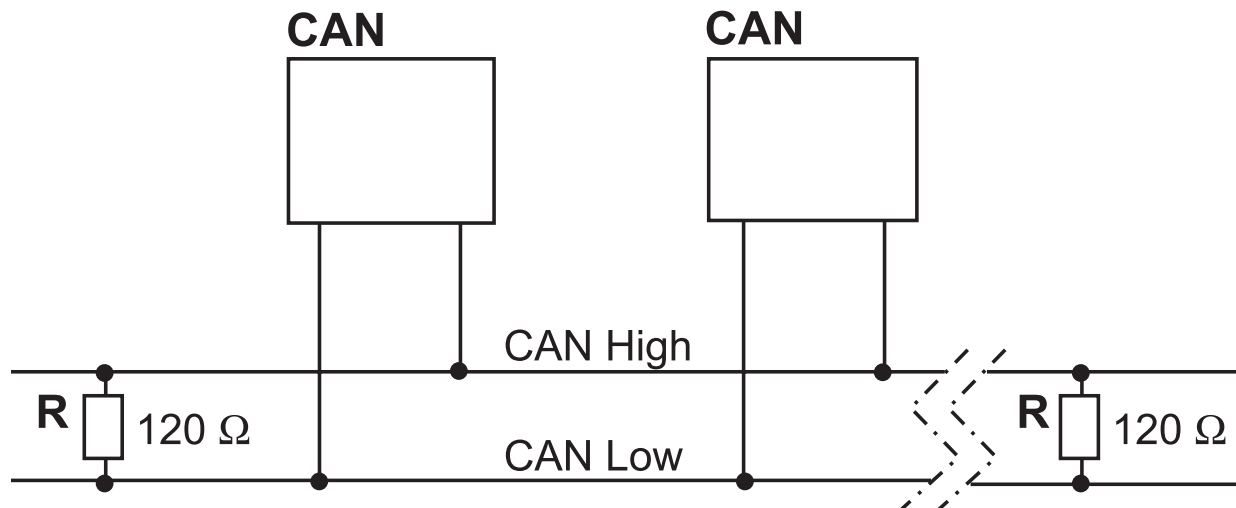

CAN CAN bus device in actuator or other equipment
 R Resistor

5. SAE J1939 CAN bus information

5.1 Introduction to SAE J1939 CAN bus

This document assumes the reader is familiar with the SAE J1939 standard. Terminology from the standard is used, but not described in detail. The default baud rate is 250kbit/s. The Electrak® XD actuator is compliant with the standard SAE J1939 and supports the following Parameter Group Numbers (PGNs) from the standard.

SAE J1939-21 – Data Link Layer

- Proprietary A 61184 (0x00EF00)
- Proprietary A2 126720 (0x01EF00)

SAE J1939-81 – Network Management

- Address Claimed/Cannot Claim 60928 (0x00EE00)
- Commanded Address 65240 (0x00FED8)

5.2 SAE J1939 CAN bus communications protocol

5.2.1 SAE J1939 NAME

The Electrak XD has the following defaults for the SAE J1939 NAME. Please refer to the SAE J1939/81 standard for more information on these parameters.

SAE J1939 NAME Defaults	
Arbitrary Address Capable	Yes
Industry Group	0, Global
Vehicle System Instance	0
Vehicle System	0, Non-specific system
Function	255, Not available
ECU Instance	0, First instance
Manufacture Code	547, Thomson Linear LLC
Identity Number	1

5.2.2 Address

The Electrak XD uses a default address value of 35 (0x23). In applications where the default address is not available, there are three additional methods in choosing a new address.

1. The Electrak XD device is arbitrary address capable. If another device with a higher priority NAME contends for the selected address, the actuator will continue to request other addresses until it finds one that it can claim.
2. The Electrak XD device can also use the commanded address PGN to select a specified address. See SAE J1939/81 for more details about address claiming.
3. In some applications, it may be more convenient to select an address through hardware switches. Activate the desired address select input by connecting it to positive and address select common to negative. This allows the user to change the default address using the address select inputs as defined in the table below. Activating individual select pins will create a binary adder to the default address. This method can allow up to 8 individual actuator addresses on a single bus. The below chart shows some examples on how this can be implemented. Note that conflicting messages produce arbitrary execution.

Address Select					
Address select common	Address select 3	Address select 2	Address select 1	Binary adder	Default address
Gnd	0	0	0	0	35 (0x23)
Gnd	0	0	1	1	36 (0x24)
Gnd	0	1	0	2	37 (0x25)
...					
Gnd	1	1	1	7	42 (0x2A)

5.2.3 SAE J1939 actuator control message (ACM)

All actuator control parameters are adjustable through the proprietary A message (PGN 61184). The preferred transmission repetition rate is 100 ms (can also be sent as required by the application). Additional message specific information can be found in the table below, all other Proprietary A information can be found in the SAE J1939/21 specification. A unit with the default address will respond to a control message with ID 0x18EF2300.

SAE J1939 Actuator Control Message (ACM)			
Parameter	Resolution/bit	Max/min value	Address [byte.bit]
Target position	0.1 mm	6553.5 mm	0.0 - 1.7
Current limit	0.1 A	6553.5 A	2.0 - 3.7
Target speed	1 mm/s	255 mm/s	4.0 - 4.7
Load limit	100 N/bit	25.5 kN	5.0 - 5.7
Factory use	-	-	6.0 - 6.7
Control bits	-	-	7.0 - 7.5

5.2.3.1 Target position

The target position for the next actuator motion. The 0.0 mm and full extend stroke values represent 0 to 100% stroke and are only relative to the actual available stroke of the individual unit.

Resolution: 0.1 mm/bit, 0 offset.

5.2.3.2 Current limit

The current at which the actuator will cease all motion. In the event a force is applied to the actuator that causes the motor current to exceed this settable value for more than 15 ms, the actuator will stop any current motion and activate a dynamic braking effect on the motor. This current limit does not apply during the motor starting phase where in rush current can be significantly higher than normal running. The current is measured at the motor phases (which is not the same as the power source current). Below chart represents the max current values for each configuration, but the actual setting should be determined based on the application. Note that the corresponding load will change with variations in actuator efficiency. Also note that the current limit is intended to protect the actuator and the equipment in case of a hard stop, and should not be used as a means to stop the actuator during normal operation.

Range: 0.0 A to max. setting in chart below.

Resolution: 0.1 A/bit, 0 offset

Maximum Current Limit Settings										
Actuator model	XD24B055	XD48B055	XD24B080	XD48B080	XD24B160	XD48B160	XD24B200	XD48B200	XD24B250	XD48B250
Max. setting	40 A	22 A	50 A	31 A	40 A	31 A	32 A	25 A	40 A	31 A

5.2.3.3 Target speed

Controls the target speed of the actuator. Can be set between 20 % of and up to the nominal speed of the actuator model. See table in section 8.1 for the speed of each actuator model. Any speed set outside the limits will result in a parameter error being sent. Example: if the speed in table 8.1 is 65 mm/s for the actuator in question, the target speed can be set between $0,2 \times 65$ to 65 mm/s (13 - 65 mm/s).

Range: 0 to 255 mm/s.

Resolution: 1 mm/s/bit, 0 offset.

5.2.3.4 Load limit

The load at which the actuator will cease all motion. If a force is applied to the actuator that causes the measured load to exceed this settable value for more than 15 ms, the actuator will stop any current motion and activate a dynamic motor braking effect. If the value is set to zero, this feature is deactivated. If both a load limit and a current limit are set, the first limit reached will stop the unit.

Range: 0 to 25.5 kN

Resolution: 100 N/bit

5.2.3.5 Control bits

Bit 0 (LSB) – Enable bit: This bit is used to enable motion from the actuator. If it is low (0), no motion will be allowed. This bit can be used to define the next actuator movement message without starting the motor. When movement is required this bit can be changed to high (1) and motion will begin using the values of the other objects contained in the RPDO.

5.2.4 SAE J1939 actuator feedback message (AFM)

All actuator feedback data can be retrieved through the proprietary A2 message (PGN 126720). This message is transmitted every 100 ms. Additional message-specific information can be found in the table below, and all other Proprietary A2 information can be found in the SAE J1939/21 specification. A unit with the default address will send out the feedback message with ID 0x19EFFF23.

SAE J1939 Actuator Feedback Message (AFM)			
Parameter	Resolution/bit	Max/min value	Address [byte.bit]
Measured position	0.1 mm	6553.5 mm	0.0 - 1.7
Measured current	0.1 A	6553.5 A	2.0 - 3.7
Measured speed	1 mm/s	255 mm/s	4.0 - 4.7
Measured load	100 N/bit	25.5 kN	5.0 - 5.7
Motion flags	-	-	6.0 - 6.7
Error flags	-	-	7.0 - 7.5

5.2.4.1 Measured position

The measured position of the actuator. The 0.0 mm and ordered full extend stroke values represent 0 to 100% stroke position but the signaled value does not take into account any mechanical tolerances or play in the actuator.

Resolution: 0.1 mm/bit, 0 offset.

Range: 0.0 mm to 1200.0 mm

Resolution: 0.1 mm/bit, 0 offset

5.2.4.2 Measured current

The motor current drawn during the active phase of the PWM duty cycle measured between the motor phases (which is not the same as the power source current).

Resolution: 0.1 A/bit, 0 offset

5.2.4.3 Measured speed

The speed measured by the actuator's internal sensors.

Resolution: 1 mm/s/bit, 0 offset.

5.2.4.4 Measured load

The load measured by the optional load sensor.

Range: 0 to 25.5 kN

Resolution 100 N/bit

5.2.4.5 Motion flags

Contains information about the current actuator motion.

Bit 0 (LSB) – Extending: 1 if currently extending, 0 otherwise.

Bit 1 – Retracting: 1 if currently retracting, 0 otherwise.

Bit2 – Saturated: 1 if the unit is moving at the maximum speed allowed by the input voltage and load. 0 otherwise.

Bit4 – Load direction. 0 at tension load, 1 at compression load.

5.2.4.6 Error flags

Contains information about actuator errors.

Bit 0 (LSB) - Parameter error: This flag is used to inform the user that one of the object values in the ACM is outside the allowed ranges of the specific model. To prevent damage to the actuator, motion is not allowed after this flag is set.

Bit 1 – Current/load overload: This flag is used to inform the user that the last motion the actuator attempted caused an overload condition. This occurs when the actuator determines the current set in the Current Limit object from the ACM is exceeded for a consecutive 15 ms. This flag is also set if the set Load Limit is exceeded (section 5.2.3.4). When this flag is set by the actuator the user must reset the Motion Enable bit in the ACM before attempting additional motion from the actuator.

Bit 2 – Voltage error: This flag is used to inform the user that the operational voltage is outside of allowable running parameters. Any motion already in progress will continue for 10 seconds, but additional movement request will not be allowed until the operational voltage returns within the normal operating range.

Bit 3- Temperature error: This flag is used to inform the user that the operational temperature is outside of allowable running parameters. Any motion already in progress will continue for 10 seconds, but additional movement request will not be allowed until the operational temperature returns within the normal operating range.

Bit 4 – Backdrive detected: This flag is used to inform the user that the actuator has determined positional movement in the extension tube that was not commanded from the user. This can be caused from excessive static load or vibration being applied to the actuator.

Bit 5 – Message timeout: this flag is used to inform the user that no control message has been received within the time specified in the timeout time settings parameter. The default value is 5000 ms.

Bit 6 – Fatal error: This flag is used to inform the user that the actuator was unable to detect any motion while trying to run the motor. When this flag is set by the actuator the user must reset the Motion Enable bit in the RPDO before attempting additional motion from the actuator. Repeated activation of this flag indicates problems with the actuator, and it is recommended to contact the factory for additional support.

Bit 7(MSB) - Memory error: This flag is used to inform the user that the internal memory of the actuator is corrupted.

6. CANopen® information

6.1 Introduction to CANopen

6.1.1 CANopen standard

This document assumes the reader is familiar with the CiA 301 specification released by CAN in Automation. Terminology from the standard is used, but not described in detail. The Electrak® XD actuator is compliant with the standard. The default baud rate is 500 kbit/s, and it will only support the standard CAN frame with 11-bit identifier field.

6.1.2 EDS file

Thomson provides an electronic data sheet file (EDS) to integrate the Electrak XD into a specific CANopen network. The EDS file can be downloaded at: www.thomsonlinear.com/en/support/docs-linear-actuators#literature

6.1.3 Node ID

The Electrak XD uses a default node ID of 35 (0x23). In applications where the default address is not available, it is possible to select an address through hardware switches. Activate the desired address select input by connecting it to positive and address select common to negative. This allows the user to change the default address using the address select inputs as defined in the table found below. Activating individual select pins will create a binary adder to the default address. This method can allow up to 8 individual actuator addresses on a single bus. The below chart shows some examples on how this can be implemented.

Address Select					
Address select common	Address select 3	Address select 2	Address select 1	Binary adder	Default address
Gnd	0	0	0	0	35 (0x23)
Gnd	0	0	1	1	36 (0x24)
Gnd	0	1	0	2	37 (0x25)
...					
Gnd	1	1	1	7	42 (0x2A)

6.1.4 NMT State

The Electrak XD supports the CANopen network management (NMT) slave state machine. It needs to be put in the operational state before operating properly.

Example:

Sending a CAN message with id 0x0, containing the data 0x01 0x00 will put all connected actuators in the operational state. Sending a CAN message with id 0x0, containing the data 0x01 0x23 will put an actuator with the default Node ID in the operational state.

6.2 Actuator control

6.2.1 Control PDO properties

Operational control of the actuator is achieved by sending the statically mapped RPDO with COB-ID \$200 + Node ID. It will have the following layout:

Byte 0	Byte 1	Byte 2	Byte 3	Byte 4	Byte 5	Byte 6	Byte 7
Target Position		Current Limit		Target Speed	Load limit	Not used	Control Bits

6.2.2 Control PDO entries

The Object Dictionary entries mapped to the RPDO are:

Index	0x2100
Name	Target Position
Object Type	VAR
Data Type	UNSIGNED16
Description	The target position for the next actuator motion. The 0.0 mm and full extend stroke values represent 0 to 100% stroke and are only relative to the actual available stroke of the individual unit. Resolution: 0.1 mm/bit, 0 offset.

Index	0x2101
Name	Current Limit
Object Type	VAR
Data Type	UNSIGNED16
Description	The current at which the actuator will cease all motion. In the event a force is applied to the actuator that causes the motor current to exceed this settable value for more than 15 ms, the actuator will stop any current motion and activate a dynamic braking effect on the motor. This current limit does not apply during the motor starting phase where in rush current can be significantly higher than normal running. The current is measured at the motor phases (which is not the same as the power source current). Below chart shows the recommended current limit values for each configuration. Note that the corresponding load will change with variations in actuator efficiency. Also note that the current limit is intended to protect the actuator and the equipment in case of a hard stop, and should not be used as a means to stop the actuator during normal operation. Range: 0.0 A to max. setting in the chart below. Resolution: 0.1 A/bit, 0 offset

Maximum Current Limit Settings

Actuator model	XD24B055	XD48B055	XD24B080	XD48B080	XD24B160	XD48B160	XD24B200	XD48B200	XD24B250	XD48B250
Max. setting	40 A	22 A	50 A	31 A	40 A	31 A	32 A	25 A	40 A	31 A

Index	0x2102
Name	Target Speed
Object Type	VAR
Data Type	UNSIGNED8
Description	Controls the target speed of the actuator. Can be set between 20 % of and up to the nominal speed of the actuator model. See table in section 8.1 for the speed of each actuator model. Any speed set outside the limits will result in a parameter error being sent. Example: if the speed in table 8.1 is 65 mm/s for the actuator in question, the target speed can be set between 0,2 × 65 to 65 mm/s (13 - 65 mm/s). Range: 0 to 255 mm/s. Resolution: 1 mm/s/bit, 0 offset.

Index	0x2103
Name	Load Limit
Object Type	VAR
Data Type	UNSIGNED8
Description	The load at which the actuator will cease all motion. In the event a force is applied to the actuator that causes the measured load to exceed this settable value for more than 15 ms, the actuator will stop any current motion and activate a dynamic braking effect on the motor. Range: 0 to 25.5 kN Resolution 100 N/bit

Index	0x2104
Name	Reserved
Object Type	VAR
Data Type	UNSIGNED8
Description	Not implemented yet, set to 0.

Index	0x2105
Name	Control Bits
Object Type	VAR
Data Type	UNSIGNED8
Description	Bit 0 (LSB) – Enable bit: This bit is used to enable motion from the actuator. If it is low (0), no motion will be allowed. This bit can be used to define the next actuator movement message without starting the motor. When movement is required this bit can be changed to high (1) and motion will begin using the values of the other objects contained in the RPDO.

6.2.3 Control PDO example

Sending a CAN message with ID 0x223 containing the data 0xE8 0x03 0x64 0x00 0x1E 0x00 0x00 0x01 will make an actuator move to position 100 mm, at 30 mm/s, with the current limit set to 10.0 A. The example will work on an actuator with the default Node ID if it is in the operational NMT state.

6.3 Actuator feedback

6.3.1 Feedback PDO properties

Operational feedback of the actuator is achieved by receiving the statically mapped TPDO with COB-ID \$180 + Node ID. It will have the following layout:

Byte 0	Byte 1	Byte 2	Byte 3	Byte 4	Byte 5	Byte 6	Byte 7
Measured Position		Measured Limit		Measured Speed	Measured Load	Motion Flags	Error Flags

6.3.2 Feedback PDO entries

The Object Dictionary entries mapped to the TPDO are:

Index	0x2200
Name	Measured Position
Object Type	VAR
Data Type	UNSIGNED16
Description	The measured position of the actuator. The 0.0 mm and ordered full extend stroke values represent 0 to 100% stroke but the signaled value does not take in to account any mechanical tolerances or play in the actuator. Resolution: 0.1 mm/bit, 0 offset.

Index	0x2201
Name	Measured Current
Object Type	VAR
Data Type	UNSIGNED16
Description	The motor current drawn during the active phase of the PWM duty cycle, which is measured between the motor phases (which is not the same as the power source current). Resolution: 0.1 A/bit, 0 offset

Index	0x2202
Name	Measured Speed
Object Type	VAR
Data Type	UNSIGNED8
Description	The speed measured by the actuator's internal sensors. Resolution: 1 mm/s/bit, 0 offset.

Index	0x2203
Name	Measured Load
Object Type	VAR
Data Type	UNSIGNED8
Description	The load measured by the optional load sensor. Range: 0 to 25.5 kN Resolution 100 N/bit

6.3.3 Motion flags

Index	0x2204
Name	Motion Flags
Object Type	VAR
Data Type	UNSIGNED8
Description	Contains information about the current actuator motion. Bit 0 (LSB) – Extending: 1 if currently extending, 0 otherwise. Bit 1 – Retracting: 1 if currently retracting, 0 otherwise. Bit 2 – Saturated: 1 if the unit is moving at the maxi. speed allowed by the input voltage and load. 0 otherwise. Bit 4 – Load direction. 0=>tension load, 1=>compression load.

6.3.4 Error flags

Index	0x2205
Name	Error Flags
Object Type	VAR
Data Type	UNSIGNED8
Description	<p>Contains information about actuator errors.</p> <p>Bit 0 (LSB) – Parameter Error: This flag is used to inform the user that one of the object values in the RPDO is outside the allowed ranges the specific model will allow. To prevent damage to the actuator motion is not allowed after this flag is set.</p> <p>Bit 1 – Current/Load Overload: This flag is used to inform the user that the last motion the actuator attempted caused an overload condition. This occurs when the actuator determines the current set in the Current Limit object from the RPDO is exceeded for a consecutive 15 ms. This flag is also set if the set Load Limit is exceeded (section 6.2.2). When this flag is set by the actuator the user must reset the Motion Enable bit in the RPDO before attempting additional motion from the actuator.</p> <p>Bit 2 – Voltage Error: This flag is used to inform the user that the operational voltage is outside of allowable running parameters. Any motion already in progress will continue for 10 seconds, but additional movement request will not be allowed until the operational voltage returns within the normal operating range.</p> <p>Bit 3 – Temperature Error: This flag is used to inform that the operational temperature is outside of allowable running parameters. Any motion already in progress will continue for 10 seconds, but additional movement request will not be allowed until the operational temperature returns within the normal operating range.</p> <p>Bit 4 – Backdrive Detected: This flag is used to inform the user that the actuator has determined positional movement in the extension tube that was not commanded from the user. This can be caused from excessive static load or vibration being applied to the actuator.</p> <p>Bit 5 – Message Timeout: This flag is used to inform the user that no RPDO has been received within the time specified in the PDO timeout time object (0x2005). When this flag is set by the actuator the user must reset the Motion Enable bit in the RPDO before attempting additional motion from the actuator. The default value is 5000 ms.</p> <p>Bit 6 – Fatal Error: This flag is used to inform the user that the actuator was unable to detect any motion while trying to run the motor. When this flag is set by the actuator the user must reset the Motion Enable bit in the RPDO before attempting additional motion from the actuator. Repeated activation of this flag indicates problems with the actuator, and it is recommended to contact the factory for additional support.</p> <p>Bit 7(MSB)- Memory Error: This flag is used to inform that the internal memory of the actuator is corrupted.</p>

7. Troubleshooting

7.1 Troubleshooting

Troubleshooting list		
Issue	Problem	Solution
Actuator does not move, makes no sound.	Actuator is not receiving proper input voltage.	Ensure the actuator is being supplied with proper rated input voltage.
The actuator, when powered, is causing my fuse to blow.	Fuse is not rated for current draw of the actuator.	Make sure that the fuse is rated for the in-rush current of the actuator, which is typically 3 times the rated current draw of the actuator at full load. Slow-blow fuses are also recommended.
My actuator intermittently stops and is hot to the touch.	The duty cycle is too high.	The duty cycle needs to be reduced which can be done by reducing the average load, lower the ambient temperature or/and make less moves per unit of time.
Actuator is sending a "fatal error" message.	The actuator is trying to move but has not detected any motion.	Check the application so that nothing has stuck. If not then actuator will need to be analyzed as an RMA (Return Material Authorization) at the manufacturing facility.
I am getting an erroneous Current overload flag (bit 1 in the error flags byte) with no load or current draw on my CNO/COO actuator. How do I fix this?	The actuator control message PGN was set up incorrectly.	"The proper command message should be 18EF2300, where 0x23 is the address of the actuator (default). Keep in mind that if the customer changes the address of the actuator with the physical addressing leads, then the command message will change as well. The address of the CAN controller should be set as something different than the actuator to prevent errors. If an ELS error (C2 on the feedback message) is encountered and the PGN is addressed correctly, simply reset the bus by sending a command message with the enable bit off, then another with it on."
When trying to move the extension tube by using the manual override input no motion takes place.	The mechanical fuse have broken due to exceeded permissible input torque.	The actuator will need to be repaired as an RMA (Return Material Authorization) at the manufacturing facility.

8. Technical specifications

8.1 Technical data

Technical Specification		XD ••	
Input voltage	[VDC]	24	48
Input voltage tolerance	[VDC]	18 - 32	36 - 60
Stroke length	[mm]	see product label	
Dynamic load (Fx), maximum	[N]	see product label	
Speed ¹	[mm/s (in/s)]		
XD24-B055		65 (2.56)	
XD48-B055		75 (2.95)	
XD24-B080		50 (1.97)	
XD48-B080		50 (1.97)	
XD24-B160		25 (0.98)	
XD48-B160		25 (0.98)	
XD24-B200		16 (0.63)	
XD48-B200		20 (0.79)	
XD24-B250		16 (0.63)	
XD48-B250		16 (0.63)	
Current draw @ rated max. load	[A]	see product label	
Weight	[kg (lbs)]	see table below	
End play, maximum	[mm (in)]	1.2 (0.047)	
Operating temperature limits, standard units	[°C (°F)]	- 40 to + 85 (- 40 to + 185)	
Max. duty cycle @ 25 °C (77 °F) @ full load @ other load	[%]	45 see section 8.2	
Restraining torque	[Nm (lbf-in)]	0 (internally restrained)	
Power supply ring terminal size		M6	
Signal connector type (connector manufacturers designation and p/n)		female 12 pin Amphenol Ecomate - RTS014N12SH03	
Protection class - static ²		IP67 / IP69K	
Protection class - dynamic ²		IP66	
Salt spray resistance	[h]	500	
Safety features static load holding brake software controlled end-of-stroke limits overload protection temperature monitoring (not on units with CAN bus option) temperature compensation voltage monitoring		yes yes yes yes yes yes	
Compliances		CE, UKCA, RoHS, REACH (EU)	

1) Speed is load independent and constant or adjustable depending on the control option being used.

2) The protection class is valid only with a mating connector attached to the signal connector in the actuator housing.

Actuator Weight																							
Mass	Ordering Stroke (S) [mm]																						
	100	150	200	250	300	350	400	450	500	550	600	650	700	750	800	850	900	950	1000	1050	1100	1150	1200
[kg]	11.9	12.4	12.9	13.5	14.0	14.5	15.0	15.6	16.1	16.6	17.1	17.7	18.2	18.7	19.2	19.8	20.3	20.8	21.3	21.9	22.4	22.9	23.4
[lbs]	26.1	27.3	28.5	29.7	30.8	32.0	33.1	34.3	35.4	36.6	37.8	39.0	40.1	41.3	42.4	43.6	44.7	45.9	47.0	48.2	49.4	50.6	51.7
	Additional weight for shock load dampening option / manual brake and override option																						
[kg]	1.16 / 0.71																						
[lbs]	2.56 / 1.56																						

8.2 Duty cycle

The max. permissible duty cycle is a function of the load and the ambient temperature. The below table is valid for 25°C (77°F). Lower temperatures will increase the duty cycle while higher temperatures will decrease it.

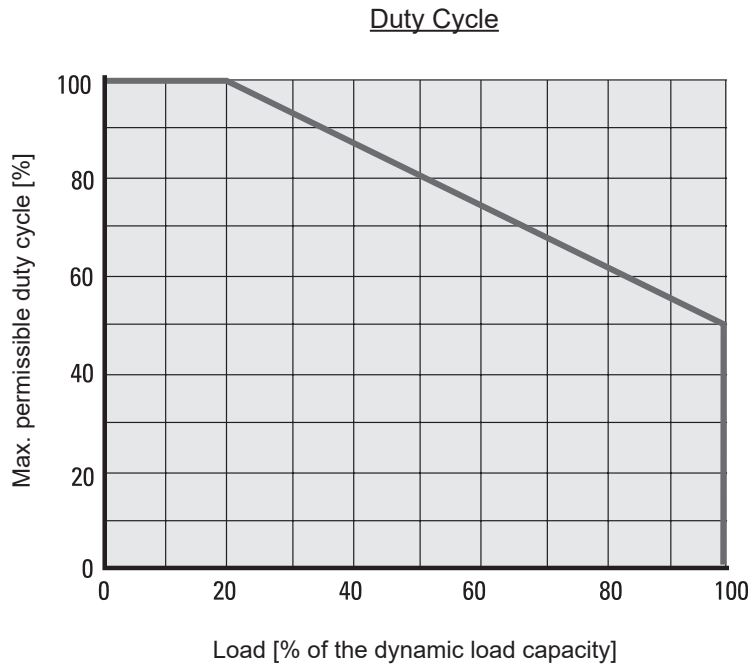

8.3 Ordering key

Ordering Key									
Position	1	2	3	4	5	6	7	8	9
Example	XD24	B055-	0200	LXX	-	M	M	S	N
<p>1. Actuator type and supply voltage XD24 = Electrak XD, 24 Vdc XD48 = Electrak XD, 48 Vdc</p> <p>2. Dynamic load capacity, speed and max. stroke length B055- = 5.5 kN @ 75 mm/s, 1200 mm B080- = 8.0 kN @ 50 mm/s, 1200 mm B160- = 16 kN @ 25mm/s, 1000 mm B200- = 20 kN @ 20 mm/s, 800 mm B250- = 25 kN @ 16 mm/s, 650 mm</p> <p>3. Ordering stroke length ^{(1) (2)} 0100 = 100 mm 0150 = 150 mm 0200 = 200 mm 0250 = 250 mm 0300 = 300 mm 0350 = 350 mm 0400 = 400 mm 0450 = 450 mm 0500 = 500 mm 0550 = 550 mm 0600 = 600 mm 0650 = 650 mm 0700 = 700 mm 0750 = 750 mm 0800 = 800 mm 0900 = 900 mm 0950 = 950 mm 1000 = 1000 mm 1050 = 1050 mm 1100 = 1100 mm 1150 = 1150 mm 1200 = 1200 mm</p>					<p>4. Electrak Modular Control System options ⁽³⁾ LXX = low-level signal motor switching + speed control + force feedback output ⁽⁴⁾ LXP = LXX + position feedback output LLX = LXX + end-of-stroke indication outputs LLP = LXX + position feedback output + end-of-stroke indication outputs PLS = LXX + position feedback output + programmable end-of-stroke software limits COO = CANopen® + closed speed control (includes diagnostics, position feedback, overload indication plus static and dynamic force feedback) ⁽⁴⁾ CNO = CAN bus SAE J1939 + closed loop speed control (includes diagnostics, position feedback, overload indication plus static and dynamic force feedback) ⁽⁴⁾</p> <p>5. Manual Brake Release and Override Option - = no manual brake release or override R = manual brake release and override</p> <p>6. Rear adapter option M = 16 mm cross hole N = 16 mm forked cross hole H = M20 × 1.5 male thread K = force feedback sensor with 16 mm cross hole ^{(4) (5)}</p> <p>7. Front adapter option M = 16 mm cross hole N = 16 mm forked cross hole H = M20 × 1.5 male thread P = M20 × 1.5 female thread</p> <p>8. Adapter orientation S = standard M = 90° turned</p> <p>9. Mechanical shock load dampening ⁽⁵⁾ N = no dampening M = dampening</p> <p>1) Max. possible stroke length depends on the dynamic load capacity, see position 2. (2) Other stroke lengths available upon request. Please contact customer support. (3) All Electrak XD are as standard equipped with the Electronic Monitoring Package. (4) To use the force feedback function, the actuator must be equipped with rear adapter type K. (5) Mechanical shock load dampening cannot be combined with force feedback.</p>				

Contact us or any of our 2000+ global distribution partners by scanning the code below
or visiting www.thomsonlinear.com/contact



RegalRexnord™
www.regalrexnord.com

www.thomsonlinear.com

Electrak_XD_Installation_Operation_MNUK-0021-05 | 20260211KB
Specifications are subject to change without notice. It is the responsibility of the product user to determine the suitability of this product for a specific application. All trademarks property of their respective owners. ©2026 Thomson Industries, Inc. | 2400 Curtiss Street, Downers Grove, IL 60515 USA

 THOMSON®