

Kollmorgen Essentials Servo System

Catalog



KOLLMORGEN

A REGAL REYNORD BRAND

Kollmorgen: Your Partner, In Motion.

Every solution comes from a real understanding of the challenges facing machine designers and users.

Innovators consistently rate Kollmorgen as one of their best motion systems manufacturing partners. Whether you are looking for classic servo motors, direct-drive servo motors, stepper motors, drives & amplifiers, gearing, actuation, or multi-axis motion controllers, Kollmorgen is one of the few companies in the world that actually designs and manufactures all of these products.

Our customers are leaders in many industries such as Aerospace & Defense, Printing, Packaging & Converting, Food & Beverage Processing, Medical Imaging, In Vitro Diagnostics & Laboratory Automation, Pharmaceutical Manufacturing, Material Forming and Cutting, Oil & Gas, and Robotics. Kollmorgen is also a leader in Warehouse Automation, including complete AGV systems, software, awareness and autonomy.

Our Automation Solutions can be found on Mars and in space, ships and submarines, O&G drilling and metrology, surgical robots and laser eye surgery, even inside artificial hearts. These are just a few applications that demand high-performance and high-quality while satisfying their specific needs.

Because motion matters, it's our focus: Motion can distinctly differentiate a specific machine and deliver a marketplace advantage by increasing its performance and dramatically improving Overall Equipment Effectiveness (OEE).

High-performance motion can make your customer's machine more reliable and energy-efficient, enhance accuracy and improve operator safety. Motion also represents endless possibilities for innovation.

We've always understood this potential, and thus have kept motion at our core and in our Vision, Mission & Values, relentlessly developing products that offer precise control of torque, velocity and position accuracy in machines that rely on complex motion.

Removing the Barriers of Design, Sourcing, and Time

At Kollmorgen, we know that OEM engineers can achieve a lot more when obstacles aren't in the way. So, we clear obstacles in three important ways:

Integrating Standard and Custom Products

The optimal solution is often not clear-cut. Our application expertise allows us to modify standard products or develop totally custom solutions across our whole product portfolio so that designs can take flight.

Providing Motion Solutions, Not Just Components

As companies reduce their supplier base and focus their engineering manpower on the product design, they need a total system supplier with a wide range of integrated solutions. Kollmorgen offers complete solutions as well as motion subsystems that combine programming software, engineering services and best-in-class motion components.

Global Footprint

With direct sales, engineering support, manufacturing facilities, and distributors spanning the Americas, Europe, the Middle East, and Asia, we're close to OEMs worldwide. Our proximity helps speed delivery and lend support where and when they're needed.

Financial and Operational Stability

Kollmorgen is part of Regal Rexnord. A key driver in the growth of all Regal Rexnord segments is the Regal Rexnord Business System, which relies on the principle of "kaizen" – or continuous improvement. Using world-class tools, cross-disciplinary teams of exceptional people evaluate processes and develop plans that result in superior performance.

Kollmorgen: Your partner. In Motion.

Table of Contents

- ▶ **Kollmorgen Essentials Servo System** 4
- ▶ **Essentials Servo Drive** 6
 - Drive Overview, Specifications, and Nomenclature
- ▶ **WorkBench Express for Essentials** 11
- ▶ **PCMM2G Essentials Controller** 12
- ▶ **Kollmorgen Automation Suite** 13
- ▶ **Essentials Servo Motor** 14
 - Essentials Servo Motor Family and Nomenclature
 - Performance Data and Motor Parameters
 - Performance Curves
 - Dimensional Drawings and Data
- ▶ **Essentials Motor Connector Pinout** 34
- ▶ **Brake Option** 34
- ▶ **Essentials SFD-M Feedback** 35
- ▶ **Essentials Technical Guide** 36
 - Bearing Fatigue and Shaft Loading
 - Thermal Device and Motor Phasing
- ▶ **Essentials System Cables** 38
 - Specifications, Nomenclature and Pinouts
- ▶ **Essentials Accessories** 40
 - Drive, Motor and Cable Accessories
- ▶ **Motors - Copyrights, Trademarks and Disclaimers** 43
- ▶ **Complete Motion and Automation Solutions** 45



Essentials Servo System

The Kollmorgen Essentials Motion System gives you Kollmorgen's renowned performance, quality and reliability at an unprecedented value.

The Kollmorgen Essentials motion system joins a comprehensive portfolio of versatile, compatible motion solutions — giving machine builders a choice of performance characteristics, features and options, cost-effective standard modifications, functional safety capabilities, environmentally resilient designs and more.

With the Kollmorgen Essentials motion system joining the complete Kollmorgen motion technology portfolio, machine designers gain a new perspective: the ability to meet practically any motion requirement and budget, today and tomorrow, with solutions and expertise from one proven partner.

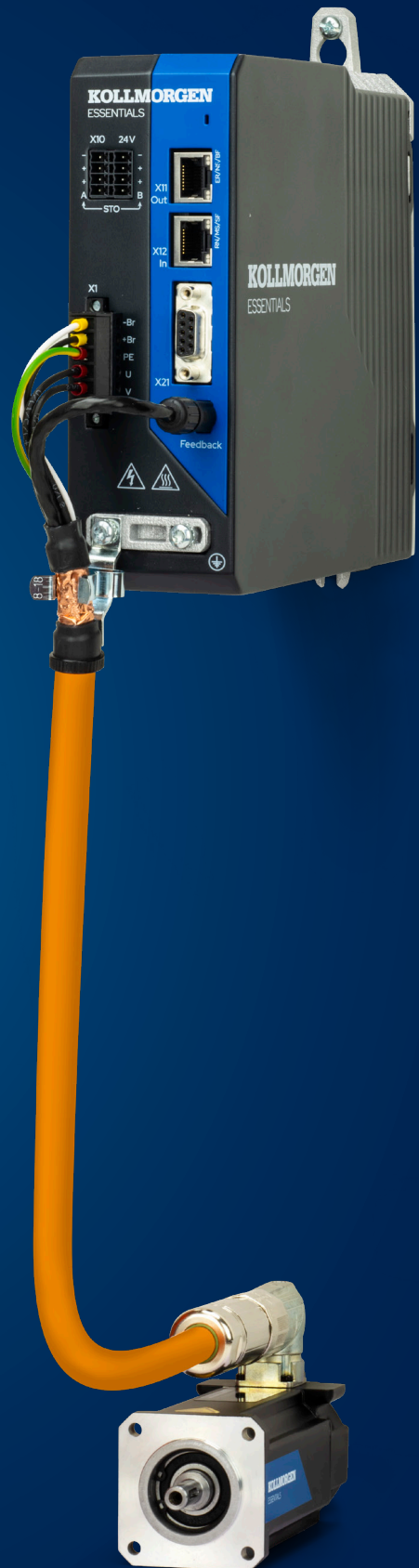

The Benefits of the Essentials Servo System

Uncompromising Performance

- » Industry-leading torque density, efficiency and reliability
- » Minimal cogging for smooth operation, even at low speeds
- » SFD-M high-resolution absolute multi-turn feedback as standard — comparable to Hiperface and EnDat feedback devices
- » Dual STO safety and motion synchronization capable

Exceptional Value In Complete Motion Solutions

- » Priced to succeed in the mid-market space
- » Multi-Ethernet feature enables compatibility with various Controls solutions within the same SKU
- » Access full parameters and tuning options in Workbench for complex axes
- » Standard batteryless, Single-cable multi-turn feedback — eliminates extra cost and complexity of a dedicated feedback power cable
- » Pre-configured to work seamlessly within Kollmorgen Automation Suite

Confident, Fast Path to Market Success

- » Count on one supplier for all your motion needs, from simple to more complex axes
- » Reduced SKUs, shorter lead times and Finished-Goods inventory ensure confidence in your supply chain
- » The new Express Setup layout with Workbench provides a pre-configured plug + play solution to enable simplified commissioning
- » The system is designed and manufactured by Kollmorgen, with each configuration validated to deliver optimum performance
- » Rely on Kollmorgen's 100+ years of leadership and financial stability

Essentials Integration with Kollmorgen Automated Motion Control Solutions



► Essentials Servo Drive

Essentials Drive: Plug In. Power Up. Perform.

The Kollmorgen Essentials Drive delivers unmatched flexibility and speed for modern machine builders. With universal connectivity—including EtherCAT, PROFINET, and EtherNet/IP—in a single drive, it seamlessly integrates with Kollmorgen Automation Suite and most Industrial Ethernet controllers.

Built-in synchronization capabilities via EtherCAT, CIP Sync and PROFINET IRT ensure precise, coordinated motion across multi-axis systems, ideal for packaging and material handling applications.

Designed for rapid deployment, the drive supports simplified installation and maintenance with single-cable feedback via SFD-M, DC bus sharing for energy efficiency as well as reduced wiring complexity and commissioning in under 20 minutes using our intuitive Express Setup layout and Quick Tune functionality within our industry-best Workbench software.





The Benefits of Essentials Servo Drives

Universal Connectivity & Integration for Advanced Motion Control

- » Supports EtherCAT, PROFINET, and EtherNet/IP — all in one drive
 - » Built-in synchronization capabilities via EtherCAT, CIP Sync and PROFINET IRT
 - » Seamlessly integrates with Kollmorgen Automation Suite and most Industrial Ethernet based motion controllers.
 - » High speed digital inputs for registration capability in the packaging and material forming industries
 - » USB-C service port for fast configuration and diagnostics.
-

Simplified Commissioning, Faster Time to Market

- » Optimized for single-cable feedback via SFD-M Multi-Turn absolute encoder (24-bit single-turn + batteryless 16-bit multi-turn resolution)
 - » Capable of DC Bus Sharing for energy efficiency, reduced wiring and reduction of components like braking resistors
 - » Commissioning in less than 20 minutes – our Express Setup layout within industry-best Workbench commissioning software enables our customers to deliver machines faster to market
 - » Quick Tune functionality offers one-button tuning, while full Workbench functionality remains available for advanced tuning and diagnostics
-

Easy-to-use Graphical User Interface (GUI) for Faster Commissioning and Troubleshooting

- » Express Setup allows quick and easy setup for less experienced engineers.
- » Auto-complete of programmable commands saves looking up parameter names.
- » Full setup included with multi-function bode plot allowing users to quickly evaluate performance
- » Six-channel real time software oscilloscope commissions and diagnoses quickly.
- » One-click capture and sharing of program plots and parameter settings allow you to send machine performance data instantly.

Essentials Servo Drive

Essentials Means Unparalleled Connectivity

Kollmorgen Essentials Drive

Kollmorgen's Essentials Drive includes all of the performance described previously, and is optimized to interface to a single-connector motor with Kollmorgen's Smart Feedback Device options (SFD-M or SFD3)

Multi-Protocol Support

No need to find the correct communication protocol option for your machine! All Essentials drives support multiple communication protocols out of the box. Just select between EtherNet/IP CIP Sync, EtherCAT or PROFINET IRT during setup.

Super-fast setup

Get your application up and running in 20 minutes or less with Kollmorgen's Express Setup layout within WorkBench, a simple, graphical configuration tool for PC that supports you throughout the entire commissioning process.

Versatile I/O

Each Kollmorgen Essentials Drive offers two fast digital inputs with <math><1 \mu s</math> reaction time, which can also be utilized for a secondary, incremental feedback solution. Two standard digital inputs and outputs are also built-in.

STO

Safety is always essential!

All Essentials drives come equipped with the certified safety function Safe Torque Off (STO), up to SIL 2 / PL d.



3-6 Amp
100-240 VAC

12 Amp
100-240 Vac
3-6 Amp
240-480 VAC

12 Amp
240-480 VAC



100-240 VAC 1-3 Φ	Continuous Current	Peak Current	Typical Shaft Power	Height	Width	Depth	Depth w/ cable bend radius
	(Arms)	(Arms)	(kW)	mm (in)	mm (in)	mm (in)	mm (in)
KED-SPM-6V03 -A100-0000-A	3	9	0.625	172 (6.77)	60 (2.36)	165 (6.50)	225 (8.86)
KED-SPM-6V06 -A100-0000-A	6	18	1.25				
KED-SPM-6V12 -A100-0000-A	12	30	2.5	200 (7.87)	70 (2.75)	202 (7.95)	262 (10.31)

240-480 VAC 3 Φ	Continuous Current	Peak Current	Typical Shaft Power	Height	Width	Depth	Depth w/ cable bend radius
	(Arms)	(Arms)	(kW)	mm (in)	mm (in)	mm (in)	mm (in)
KED-SPM-7V03 -A100-0000-A	3	9	1.5	200 (7.87)	70 (2.75)	202 (7.95)	262 (10.31)
KED-SPM-7V06 -A100-0000-A	6	18	2.5				
KED-SPM-7V12 -A100-0000-A	12	30	5	220 (8.66)			

Essentials Drive Connector Layout

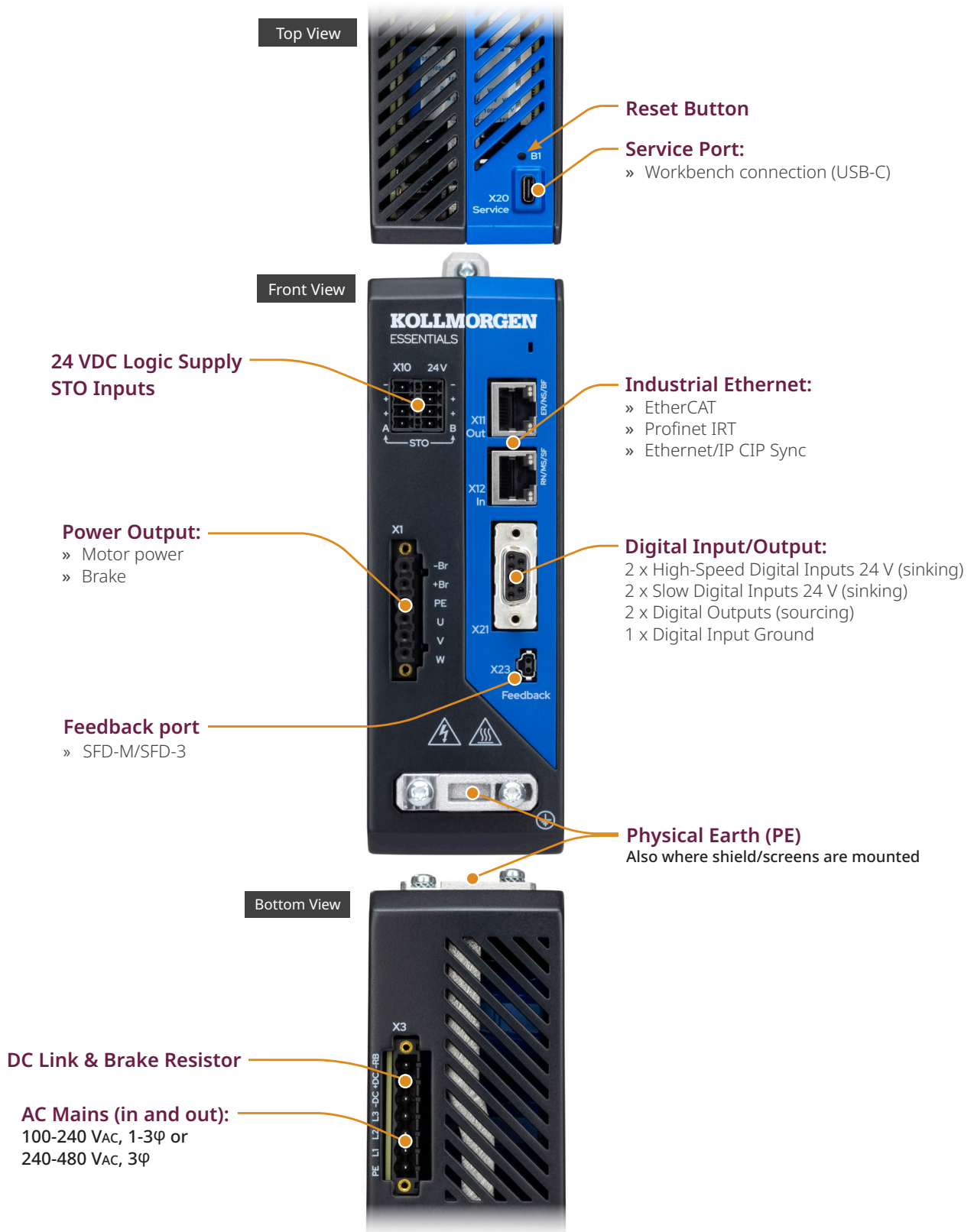

Essentials Servo Drive

Kollmorgen Essentials Drive Model Nomenclature

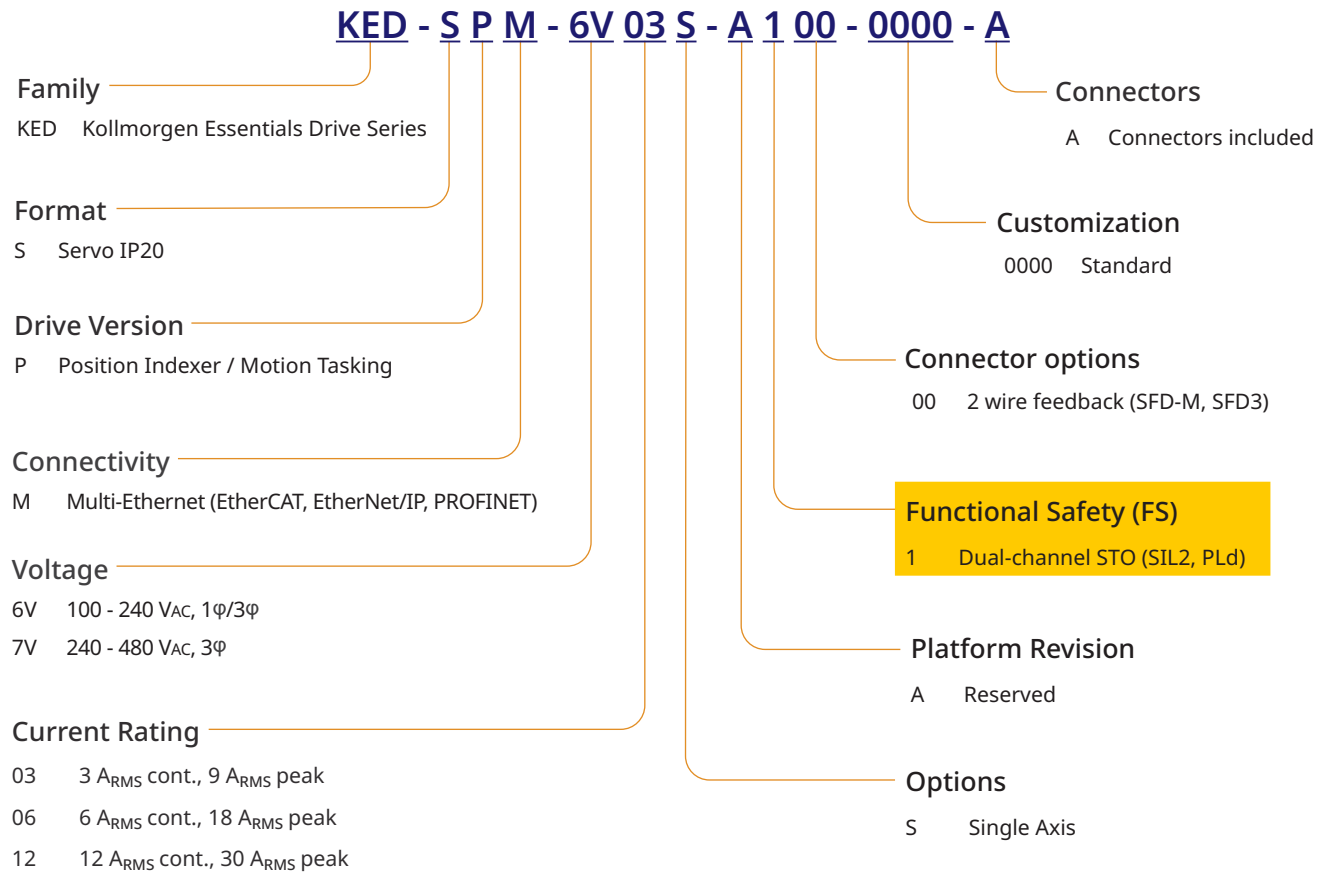

Kollmorgen Essentials Drive Options 100-240 VAC, 1 ϕ /3 ϕ

- KED-SPM-6V03S-A100-0000-A
- KED-SPM-6V06S-A100-0000-A
- KED-SPM-6V12S-A100-0000-A

Kollmorgen Essentials Drive Options 240-480 VAC, 3 ϕ

- KED-SPM-7V03S-A100-0000-A
- KED-SPM-7V06S-A100-0000-A
- KED-SPM-7V12S-A100-0000-A



KOLLMORGEN WorkBench

with Express Setup for Essentials



Our simple Graphical User Interface (GUI), Kollmorgen WorkBench, is designed to expedite and streamline the user's experience with the Essentials family of servo drives. From easy application selection and reduced math, to a sleek six-channel scope; the user interface is extremely easy to use. The new Express Setup view guides you quickly through system commissioning. Configuring fieldbus protocols, power, motors and I/O is a breeze. Easy as 1 - 2 - 3!



1 Launch WorkBench and connect the drive. Once connected, the Express Setup pane is opened.



2 Express Setup quickly guides you through the required settings to have your system up and running in minutes.



3 Express Setup monitors the setup process and ensures all required settings have been addressed before enabling the system.



4 Your system is up and running!

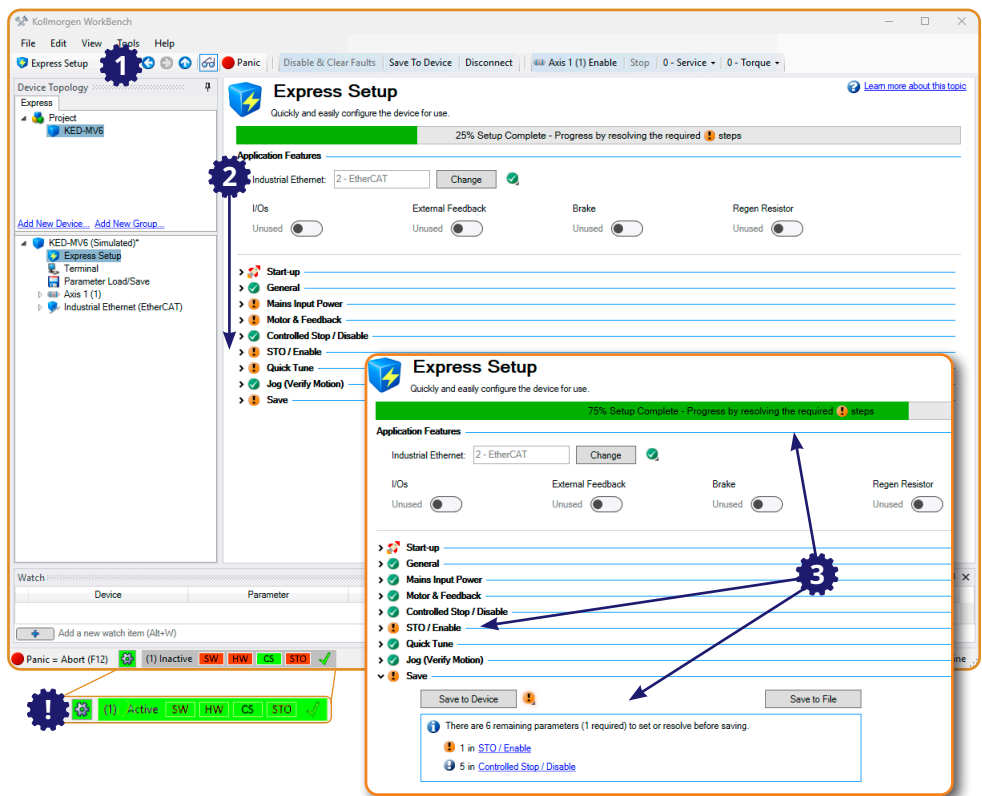

5 Switch to Full Setup mode to reveal and explore all of the available WorkBench features:

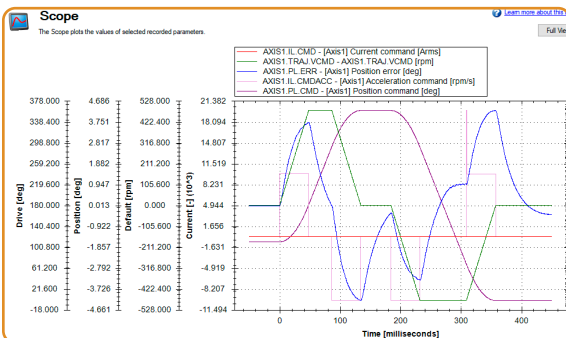

“Real-time” Oscilloscope, Application Selection, Motion Tasks, Performance Tuning, Cogging Compensation, and many more...

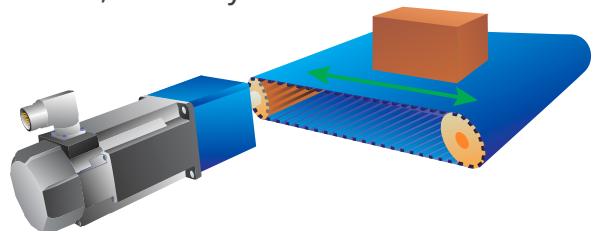

PCMM2G Essentials Controller



Kollmorgen's PCMM2G Essentials controller provides proven PCMM2G performance and integration capabilities at a price point scaled for lower-axis-count applications. As part of a complete Kollmorgen Essentials Motion System and seamless integration with the Kollmorgen Automation Suite (KAS), the controller simplifies design, accelerates commissioning and maximizes overall system value.

- » Scalable controller platform for lower-axis machines
- » Up to 8 axes of synchronized path motion for indexing and basic positioning tasks
- » Integrated I/O and functional safety modules
- » Plug-and-play capabilities with KAS and third-party systems
- » Includes lifelong software updates and no additional licensing fees through KAS
- » Faster setup and commissioning with pre-integrated components
- » Built-in tools for rapid configuration, tuning and optimization
- » Flexible programming options include PLCopen and IEC 61131-3 programming

For higher-axis machines and more complex motion requirements, Kollmorgen offers the PCMM2G general automation controller that supports up to 64 axes of motion.

Specifications

Processor	Quad-core 1.5 GHz (ARM Cortex A-72 processor)	Critical Temperature Limit (CPU)	83 °C/180 °C
Internal Memory	2 GB RAM, 8 GB Flash memory	Dimensions	174 mm (H) x 50 mm (W) x 111.5 mm (D)
Motion Network	EtherCAT, max 4 kHz update rate	External Memory	Removable USB flash drive slot. USB flash drive not included.
Networking Protocols	2 Ethernet Ports 100BaseT connection supporting: <ul style="list-style-type: none"> » OPC-UA » EtherNet/IP » HTTP » Modbus TCP » PROFINET » TCP/IP » UDP 	Input Power	24 Vdc @ 1.25 A
Certifications	CE, RoHS, UKCA, UL	Local I/O	6 digital inputs 2 digital outputs
Battery	<ul style="list-style-type: none"> » CR2032 Lithium Manganese Dioxide primary cell, 3V. » At least 190 mAh 	Operating Temperature (ambient range)	0 °C to 55 °C
		Sealing	IP20

PCMM2G Model Nomenclature

PCMM2G - C2 - 08 - 024 - 00 - 0000

Platform	PCMM2G 2nd Generation Multi-Axis Controller	Customization	0000 Standard A000 Conformal Coated
Processor/RAM	C2 1.5 GHz Quad-core / 2 GB	Form Factor	00 Panel Mount
Storage	08 8 GB	Controller Model	008 Essentials, 0-8 Axes 024 Standard, 0-24 Axes 064 Advanced, 0-64 Axes

Kollmorgen Automation Suite

A Fully Integrated System

Today's OEMs must deliver differentiated, high-performance machines, quickly, to stay competitive. The Kollmorgen Automation Suite (KAS) enables this, with a complete software and hardware package proven to measurably accelerate development, increase throughput, minimize scrap and maximize overall equipment effectiveness.

The Kollmorgen Automation Suite (KAS), controllers, drives, motors, I/O and cables all come together in an integrated system to fully automate and control every axis of your entire application. This gives machine builders the flexibility to scale performance and cost across a wide range of applications, while reducing integration effort and simplifying design.

Single point of control

Faster, more efficient motion design starts with the KAS Integrated Development Environment. This platform features all the tools to design, program, configure, debug and maintain machine applications—all from a single connection.

Integrated safety at every step

KAS integrates safety for all components of the control system. SafeMotion capabilities ensure local drive safety, while the SafePLC2 programming environment provides certified functional safety and system-level I/O control.

Programming made easy

KAS helps you achieve better machine control, faster. It supports the industry-standard IEC 61131-3 programming toolkit with automated features and offers plug-and-play design and easy-to-use function blocks for speed and efficiency.

Seamless connectivity

An integrated OPC UA Server connects HMIs and other controllers, while an on-board Web Server enables browser-based diagnostics and control. Plus, Network Time Protocol (NTP) ensures synchronized timing for highly coordinated motion.

Built-in tools to enhance performance

Digital diagnostic and troubleshooting features make setup and tuning intuitive, while comprehensive simulation tools further support application development and debugging without requiring hardware



Essentials Servo Motor

Essentials Motor: One Motor, Endless Possibilities

The Kollmorgen Essentials Motor is engineered for versatility, performance, and simplicity. Featuring integrated SFD-M multi-turn absolute feedback and a universal IEC mount with an adaptable shaft option, it empowers machine builders to streamline inventory and reduce complexity.

When paired with the Essentials Drive, a single platform can address up to 12 configuration needs—eliminating costly downtime waiting for specialized products and reducing part variability by 90%. With plug-and-play commissioning via onboard memory in the feedback device, and a single-cable design, installation is effortless.

Available in power ranges from 200W to 4000W and speeds up to 6000 rpm, this motor is built to meet global demands in the packaging, material handling, and factory automation markets—reliably and efficiently.





The Benefits of Essentials Servo Motors

- Versatile Functionality, Streamlined Supply Chain**
- » Integrated multi-turn absolute encoder feedback enables machine builders to use same motor for requirements spanning from high-resolution for precision control to long linear travels or high gear ratios.
 - » Industry-common IEC motor mount and innovative key kit supports adaptable motor mounting to standard mechanical interfaces such as gearboxes and coupling types requiring either smooth or keyed shafts
 - » When paired with our Essentials drive, featuring multi-Ethernet protocol capability, machine builders and integrators can use 1 platform to solve 12 different configuration requirements, which is a 90% configuration reduction (2 feedback capabilities – single-turn or multi-turn, 2 shaft configurations – smooth or keyed, 3 communication protocols – EtherCAT, Ethernet/IP and PROFINET)
 - » Optional 24 Vdc brake and field-installable IP65 shaft seal kits available

- Simplified Commissioning, Faster Time to Market**
- » Single cable design with SpeedTec connectors and batteryless multi-turn functionality simplifies installation and long-term maintenance while ensuring high reliability
 - » Onboard memory in our smart feedback device (SFD-M) enables “plug-and-play” parametrization with Kollmorgen drives

Trusted Performance and Quality

- » System offerings ranging from 200W to 4000W with windings optimized for 120, 240, 400 or 480 VAC inputs to support the most common, global application requirements
- » Rated speeds of 3000 rpm with maximum speed capability up to 6000 rpm to meet the demands of common packaging, material handling and warehouse automation applications.
- » Solutions designed and manufactured within Kollmorgen facilities. Reliable solutions, readily available.



Essentials Servo Motor

Essentials Motors Offer High Performance at an Exceptional Value

The Essentials high-performance motor series offers a curated selection of mounting, connectivity and feedback options intended to suit the widest range of applications while providing the best value to our customers. These motors offer superb flexibility to meet application needs with:

- 4 frame sizes (58 to 138 mm)
- 2 rated power options per frame size
- Multi-turn absolute SFD-M encoder (Smart Feedback Device)

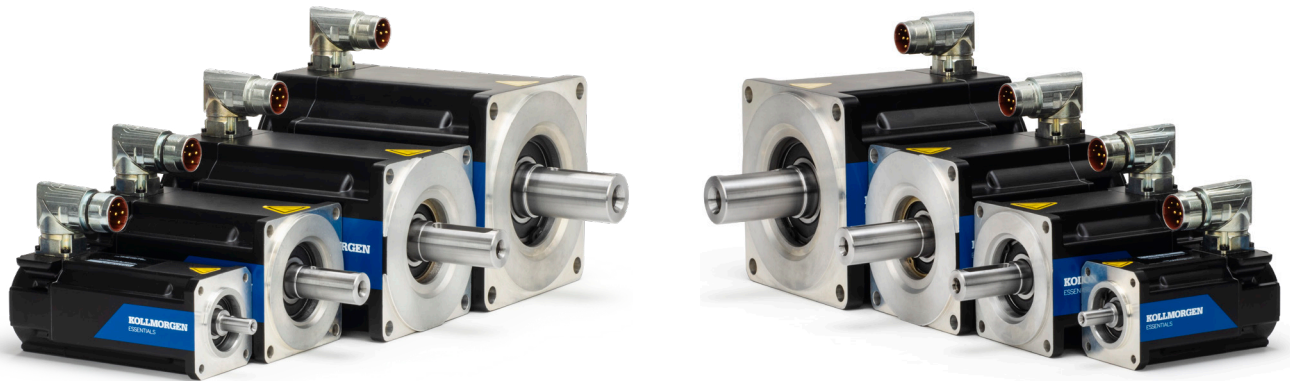

Features

Torque

0.74 to 17.4 Nm continuous stall torque (6.55 to 154 lb-in) in 14 frame/stack/winding combinations.

Speed

Rated speeds of 3000 rpm, with maximum speeds up to 6000 rpm, meet application requirements of the warehouse automation, packaging and material handling industries.

Voltage

Essentials motors can be applied to all standard global voltages. Windings are specifically tailored to work with drives powered by 100-240 VAC 1-3 ϕ , or 240-480 VAC 3 ϕ , voltage supplies.

Mounting

The Essentials shaft-mount is designed to meet industry-common IEC standards. The innovative key kit provides users with smooth or keyed shaft adaptability within a singular SKU, enabling them to stock a versatile system to solve numerous application requirements.

Feedback

Essentials motors include the SFD-M multi-turn absolute feedback device, offering 24-bit single-turn and 16-bit batteryless multi-turn resolution.

Connectivity

Single, rotatable IP65 connector (combined power, brake and feedback) is provided to minimize cabling requirements and reduce setup time.

Thermal

Windings are rated conservatively at 100 °C rise over a 40 °C ambient while using 155 °C (class F) insulation materials. Motors meet applicable UL, CSA, and CE requirements and include thermistors.

Additional Options:

- » 24 Vdc Holding Brakes
- » Field-installable IP65 shaft seal kit available (additional accessory)

Kollmorgen Essentials Servo Motor Features



Essentials Servo Motor Family

Offering a broad power range along with durability and economy

KEM-2V020/KEM-xV040

Flange: 58 mm
Power: 200 - 400 W
Rated Speed: 3000 RPM
Max Speed: 6000 RPM
Continuous Torque: 0.74 - 1.4 Nm



KEM-xV075/KEM-xV100

Flange: 84 mm
Power: 750 - 1000 W
Rated Speed: 3000 RPM
Max Speed: 6000 RPM
Continuous Torque: 2.74 - 3.63 Nm



KEM-xV150/KEM-xV250

Flange: 108 mm
Power: 1500-2000 W
Rated Speed: 3000 RPM
Max Speed: 5000 RPM
Continuous Torque: 5.9 - 10.1 Nm



KEM-xV300/KEM-4V400

Flange: 138 mm
Power: 3000 - 4000 W
Rated Speed: 3000 RPM
Max Speed: 4000 RPM
Continuous Torque: 11.5 - 17.4 Nm



Kollmorgen Essentials Brushless Servo Motor Nomenclature

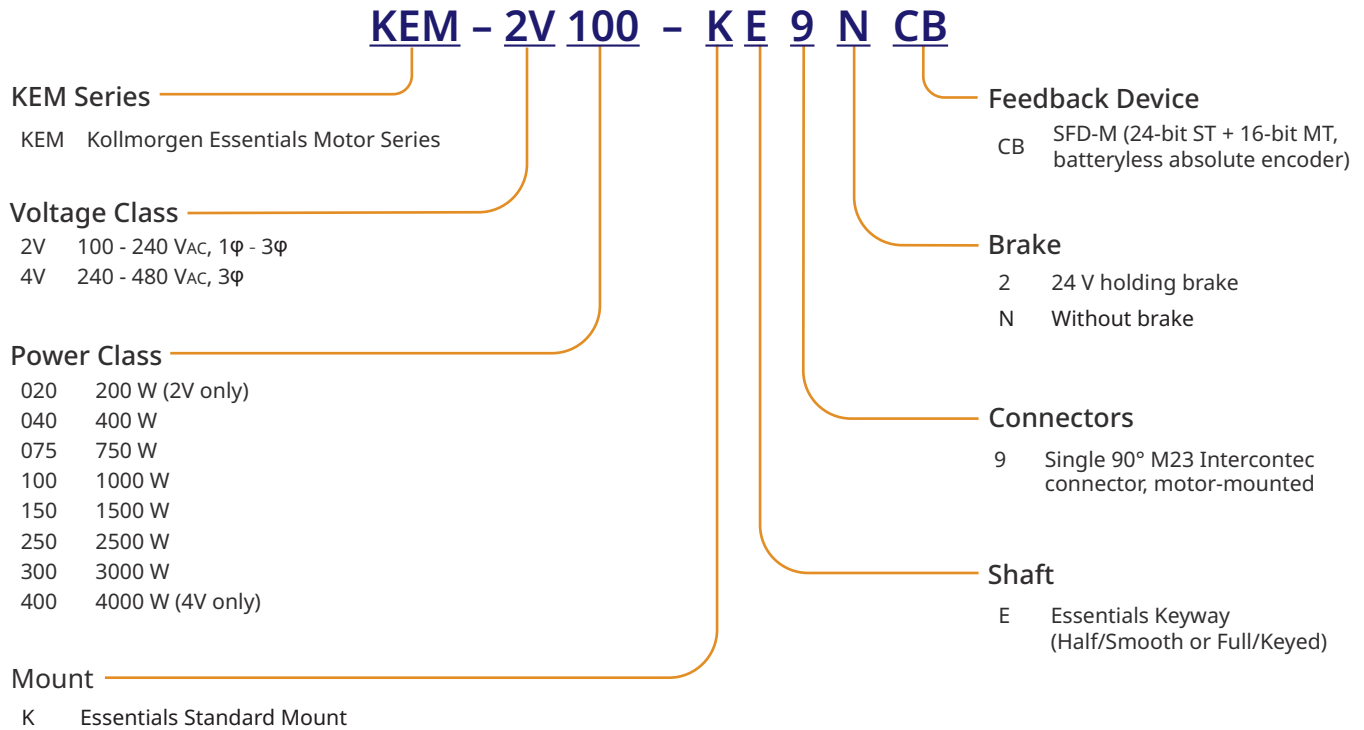

Kollmorgen Essentials Motor Options 100-240 VAC Rated

- KEM-2V020-KE9NCB
- KEM-2V020-KE92CB
- KEM-2V040-KE9NCB
- KEM-2V040-KE92CB
- KEM-2V075-KE9NCB
- KEM-2V075-KE92CB
- KEM-2V100-KE9NCB
- KEM-2V100-KE92CB
- KEM-2V150-KE9NCB
- KEM-2V150-KE92CB
- KEM-2V250-KE9NCB
- KEM-2V250-KE92CB
- KEM-2V300-KE9NCB
- KEM-2V300-KE92CB

Kollmorgen Essentials Motor Options 240-480 VAC Rated

- KEM-4V040-KE9NCB
- KEM-4V040-KE92CB
- KEM-4V075-KE9NCB
- KEM-4V075-KE92CB
- KEM-4V100-KE9NCB
- KEM-4V100-KE92CB
- KEM-4V150-KE9NCB
- KEM-4V150-KE92CB
- KEM-4V250-KE9NCB
- KEM-4V250-KE92CB
- KEM-4V300-KE9NCB
- KEM-4V300-KE92CB
- KEM-4V400-KE9NCB
- KEM-4V400-KE92CB

Essentials Motor Specifications

KEM-2V020/KEM-xV040 (200W/400W) Performance Data – Up to 480 Vac (640 Vdc Bus)

KEM-2V020/KEM-xV040 - 58 mm Flange Series

				KEM-2V-				KEM-4V-	
				020		040		040	
Parameters	Tol	Symbol	Units	No Brake	w/ Brake	No Brake	w/ Brake	No Brake	w/ Brake
Max Rated Voltage	Max	-	Vac	240		240		480	
Continuous Torque for ΔT winding = 100 °C ①②⑦	Nom	T_{CS}	Nm	0.74	0.73	1.40	1.32	1.37	1.29
			lb-in	6.5	6.5	12.4	11.7	12.1	11.4
Continuous Current for ΔT winding = 100 °C ①②⑦	Nom	I_{CS}	A_{RMS}	1.56	1.54	2.50	2.36	1.45	1.37
Continuous Torque for ΔT winding = 60 °C ②⑦	Nom	T_{CS}	Nm	0.59	0.58	1.12	1.06	1.10	1.03
			lb-in	5.2	5.1	9.9	9.4	9.7	9.1
Max Mechanical Speed ⑤	Nom	N_{max}	rpm	6000		6000		6000	
Peak Torque ①②	Nom	T_p	Nm	2.09		3.96		3.89	
			lb-in	18.5		35		34.4	
Peak Current	Nom	I_p	A_{RMS}	4.7		7.50		4.35	
Rated Torque (speed) ①②⑦		T_{Rtd}	Nm	0.74	0.72	1.37	1.30	1.36	1.28
			lb-in	6.5	6.4	12.1	11.5	12.0	11.3
Rated Speed		N_{Rtd}	rpm	1000		1000		500	
Rated Power (speed) ①②⑦		P_{Rtd}	W	0.08	0.08	0.14	0.14	0.07	
			Hp	0.11	0.11	0.19	.019	0.09	
Rated Torque (speed) ①②⑦		T_{Rtd}	Nm	0.70	0.67	1.30	1.25	1.33	1.27
			lb-in	6.2	5.9	11.5	11.1	11.8	11.2
Rated Speed		N_{Rtd}	rpm	3000		3000		1500	
Rated Power (speed) ①②⑦		P_{Rtd}	kW	0.22	0.21	0.41	0.39	0.21	0.20
			Hp	0.30	0.28	0.55	0.52	0.28	0.27
Rated Torque (speed) ①②⑦		T_{Rtd}	Nm	-	-	-	-	1.28	1.23
			lb-in	-	-	-	-	11.3	10.9
Rated Speed		N_{Rtd}	rpm	-		-		3000	
Rated Power (speed) ①②⑦		P_{Rtd}	kW	-	-	-	-	0.40	0.39
			Hp	-	-	-	-	0.54	0.52
Rated Torque (speed) ①②⑦		T_{Rtd}	Nm	-	-	-	-	1.27	1.22
			lb-in	-	-	-	-	11.2	10.8
Rated Speed		N_{Rtd}	rpm	-		-		3000	
Rated Power (speed) ①②⑦		P_{Rtd}	kW	-	-	-	-	0.40	0.38
			Hp	-	-	-	-	0.54	0.51

Notes:

- ① Motor winding temperature rise, $\Delta T = 100$ °C, at 40 °C ambient.
- ② All data referenced to sinusoidal commutation.
- ③ Add brake inertia if applicable for total inertia.
- ④ Motor with standard heat sink.
- ⑤ May be limited at some values of Vbus.
- ⑥ Measured at 25 °C.
- ⑦ For motors with optional shaft seal, reduce torque shown by 0.047 Nm, and increase T_f by the same amount.
- ⑧ Brake option increases weight by 0.27 kg (0.60 lb).

KEM-2V020/KEM-xV040 (200W/400W) Motor Parameters

KEM-2V020/KEM-xV040 - 58 mm Flange Series				KEM-2V-	KEM-2V-	KEM-4V-
Parameters	Tol	Symbol	Units	020	040	
Torque Constant ①	±10%	K _t	Nm/A _{rms}	0.48	0.57	0.96
			lb-in/A _{rms}	4.25	5.0	8.5
Back EMF Constant ②	±10%	K _e	V _{rms} /krpm	30.9	36.6	62.0
Motor Constant	Nom	K _m	N-m/√W	0.110	0.175	0.170
			lb-in/√W	0.97	1.55	1.52
Resistance (line-line) ③	±10%	R _m	ohm	12.9	7.0	20.8
Inductance (line-line)		L	mH	21.2	14.1	40.4
Inertia (includes SFD-M feedback) ③	±10%	J _m	kg-cm ²	0.118	0.209	
			lb-in-s ²	1.0E-04	1.8E-04	
Optional Brake Inertia (additional)	±10%	J _m	kg-cm ²	0.018		
			lb-in-s ²	1.6E-05		
Weight (w/o brake) ④		W	kg	1.08	1.48	
			lb	2.4	3.3	
Static Friction ⑤⑦		T _f	Nm	0.012	0.018	
			lb-in	0.11	0.16	
Viscous Damping ①		K _{dv}	Nm/krpm	0.004	0.008	
			lb-in/krpm	0.035	0.071	
Thermal Time Constant		TCT	minutes	7	9	
Thermal Resistance		R _{thw-a}	°C/W	1.47	1.06	
Pole Pairs				6		
Heat Sink Size ④				10"x10"x0.25" Aluminum Plate		

Notes:

- ① Motor winding temperature rise, ΔT = 100 °C, at 40 °C ambient.
- ② All data referenced to sinusoidal commutation.
- ③ Add brake inertia if applicable for total inertia.
- ④ Motor with standard heat sink.
- ⑤ May be limited at some values of V_{bus}.
- ⑥ Measured at 25 °C.
- ⑦ For motors with optional shaft seal, reduce torque shown by 0.047 Nm, and increase T_f by the same amount.
- ⑧ Brake option increases weight by 0.27 kg (0.60 lb).

Essentials Motor Specifications

KEM-xV075/KEM-xV100 (750W/1000W) Performance Data – Up to 480 V_{ac} (640 V_{dc} Bus)

KEM-xV075/KEM-xV100 – 84 mm Flange Series

Parameters	Tol	Symbol	Units	KEM-2V-				KEM-4V-			
				075		100		075		100	
				No Brake	w/ Brake	No Brake	w/ Brake	No Brake	w/ Brake	No Brake	w/ Brake
Max Rated Voltage	Max	-	V _{ac}	240		240		480		480	
Continuous Torque for ΔT winding = 100 °C ①②⑦	Nom	T_{CS}	Nm	2.74	2.67	3.63	3.57	2.68	2.61	3.64	3.57
			lb-in	24.2	23.6	32.1	31.6	23.7	23.1	32.2	31.6
Continuous Current for ΔT winding = 100 °C ①②⑦	Nom	I_{CS}	A_{RMS}	3.85	3.76	4.76	4.67	2.47	2.41	3.06	3.00
Continuous Torque for ΔT winding = 60 °C ②⑦	Nom	T_{CS}	Nm	2.19	2.14	2.90	2.86	2.14	2.09	2.91	2.86
			lb-in	19.4	18.9	25.7	25.3	18.9	18.5	25.8	25.3
Max Mechanical Speed ⑤	Nom	N_{max}	rpm	6000		6000		6000		6000	
Peak Torque ①②	Nom	T_p	Nm	7.2		9.7		7.0		9.7	
			lb-in	64		86		62		86	
Peak Current	Nom	I_p	A_{RMS}	11.6		14.3		7.4		9.2	
120 V _{ac} Rated Torque (speed) ①②⑦		T_{Rtd}	Nm	2.69	2.62	3.56	3.48	2.65	2.58	3.61	3.53
			lb-in	23.8	23.2	31.5	30.8	23.5	22.8	31.9	31.2
120 V _{ac} Rated Speed		N_{Rtd}	rpm	1000		1000		500		500	
120 V _{ac} Rated Power (speed) ①②⑦		P_{Rtd}	W	0.28	0.27	0.37	0.36	0.14	0.14	0.19	0.18
			Hp	0.38	0.36	0.50	0.48	0.19	0.19	0.25	0.24
240 V _{ac} Rated Torque (speed) ①②⑦		T_{Rtd}	Nm	2.52	2.44	3.30	3.19	2.55	2.48	3.46	3.37
			lb-in	22.3	21.6	29.2	28.2	22.6	21.9	30.6	29.8
240 V _{ac} Rated Speed		N_{Rtd}	rpm	3000		3000		2000		2000	
240 V _{ac} Rated Power (speed) ①②⑦		P_{Rtd}	kW	0.79	0.77	1.04	1.00	0.53	0.52	0.72	0.71
			Hp	1.06	1.03	1.39	1.34	0.71	0.70	0.97	0.95
400 V _{ac} Rated Torque (speed) ①②⑦		T_{Rtd}	Nm	-	-	-	-	2.44	2.37	3.29	3.19
			lb-in	-	-	-	-	21.6	21.0	29.1	28.2
400 V _{ac} Rated Speed		N_{Rtd}	rpm	-	-	-	-	3000		3000	
400 V _{ac} Rated Power (speed) ①②⑦		P_{Rtd}	kW	-	-	-	-	0.77	0.74	1.03	1.00
			Hp	-	-	-	-	1.03	0.99	1.38	1.34
480 V _{ac} Rated Torque (speed) ①②⑦		T_{Rtd}	Nm	-	-	-	-	2.43	2.36	3.25	3.15
			lb-in	-	-	-	-	21.5	20.9	28.8	27.9
480 V _{ac} Rated Speed		N_{Rtd}	rpm	-	-	-	-	3000		3000	
480 V _{ac} Rated Power (speed) ①②⑦		P_{Rtd}	kW	-	-	-	-	0.76	0.74	1.02	0.99
			Hp	-	-	-	-	1.02	0.99	1.37	1.33

Notes:

- ① Motor winding temperature rise, $\Delta T = 100$ °C, at 40 °C ambient.
- ② All data referenced to sinusoidal commutation.
- ③ Add brake inertia if applicable for total inertia.
- ④ Motor with standard heat sink.
- ⑤ May be limited at some values of V_{bus} .
- ⑥ Measured at 25 °C.
- ⑦ For motors with optional shaft seal, reduce torque shown by 0.071 Nm, and increase T_i by the same amount.
- ⑧ Brake option increases weight by 0.69 kg (1.52 lb).

KEM-xV075/KEM-xV100 (750W/1000W) Motor Parameters

KEM-xV075/KEM-xV100 – 84 mm Flange Series				KEM-2V-	KEM-4V-	KEM-2V-	KEM-4V-
Parameters	Tol	Symbol	Units	075		100	
Torque Constant ①	±10%	K _t	Nm/A _{rms}	0.72	1.1	0.77	1.2
			lb-in/A _{rms}	6.4	9.7	6.8	10.6
Back EMF Constant ②	±10%	K _e	V _{rms} /krpm	46.4	71	50	78
Motor Constant	Nom	K _m	N-m/√W	0.325	0.32	0.41	0.41
			lb-in/√W	2.88	2.82	3.63	3.63
Resistance (line-line) ⑥	±10%	R _m	ohm	3.28	8.0	2.35	5.7
Inductance (line-line)		L	mH	9.9	22.9	7.5	18.2
Inertia (includes SFD-M feedback) ③	±10%	J _m	kg-cm ²	0.950		1.350	
			lb-in-s ²	8.4E-04		1.2E-03	
Optional Brake Inertia (additional)	±10%	J _m	kg-cm ²	0.070			
			lb-in-s ²	6.2E-05			
Weight (w/o brake) ⑧		W	kg	2.61		3.11	
			lb	5.8		6.9	
Static Friction ①⑦		T _f	Nm	0.037		0.042	
			lb-in	0.33		0.37	
Viscous Damping ①		K _{dv}	Nm/krpm	0.014		0.017	
			lb-in/krpm	0.124		0.150	
Thermal Time Constant		TCT	minutes	12		15	
Thermal Resistance		R _{thw-a}	°C/W	0.95		0.87	
Pole Pairs				5			
Heat Sink Size ④				10"x10"x0.25" Aluminum Plate			

Notes:

- ① Motor winding temperature rise, ΔT = 100 °C, at 40 °C ambient.
- ② All data referenced to sinusoidal commutation.
- ③ Add brake inertia if applicable for total inertia.
- ④ Motor with standard heat sink.
- ⑤ May be limited at some values of V_{bus}.
- ⑥ Measured at 25 °C.
- ⑦ For motors with optional shaft seal, reduce torque shown by 0.071 Nm, and increase T_f by the same amount.
- ⑧ Brake option increases weight by 0.69 kg (1.52 lb).

Essentials Motor Specifications

KEM-xV150/KEM-xV250 (1500W/2500W) Performance Data – Up to 480 V_{AC} (640 V_{DC} Bus)

KEM-xV150/KEM-xV250 – 108 mm Flange Series

Parameters				KEM-2V-				KEM-4V-			
				150		250		150		250	
	Tol	Symbol	Units	No Brake	w/ Brake	No Brake	w/ Brake	No Brake	w/ Brake	No Brake	w/ Brake
Max Rated Voltage	Max	-	V _{AC}	240		240		480		480	
Continuous Torque for ΔT winding = 100 °C ①②⑦	Nom	T _{CS}	Nm	5.9		10.1		5.8	5.7	10.1	10.1
			lb-in	52		89		51	50	89	89
Continuous Current for ΔT winding = 100 °C ①②⑦	Nom	I _{CS}	A _{RMS}	8.0	7.9	10.9	10.9	4.58	4.56	6.9	6.9
Continuous Torque for ΔT winding = 60 °C ②⑦	Nom	T _{CS}	Nm	4.72		8.1		4.64	4.56	8.1	8.1
			lb-in	41.8		72		41.1	40.4	72	72
Max Mechanical Speed ⑥	Nom	N _{max}	rpm	5000		5000		5000		5000	
Peak Torque ①②	Nom	T _p	Nm	13.3		23.4		13.1		23.4	
			lb-in	118		207		116		207	
Peak Current	Nom	I _p	A _{RMS}	20.0		27.2		11.5		17.2	
120 V _{AC} Rated Torque (speed) ①②⑦		T _{rtd}	Nm	5.6	9.8	9.7	5.7	10.0			
			lb-in	49.6	87	86	50	89			
Rated Speed		N _{rtd}	rpm	1500		1000		500		500	
Rated Power (speed) ①②⑦		P _{rtd}	W	0.88	1.03	1.02	0.3	0.52			
			Hp	1.18	1.38	1.37	0.4	0.7			
240 V _{AC} Rated Torque (speed) ①②⑦		T _{rtd}	Nm	5.1	8.6	8.5	5.4	9.6	9.5		
			lb-in	45.1	76	75	47.8	85	84		
Rated Speed		N _{rtd}	rpm	3000		3000		2000		1500	
Rated Power (speed) ①②⑦		P _{rtd}	kW	1.6	2.7	2.67	1.13	1.51	1.49		
			Hp	2.15	3.62	3.58	1.52	2.02	2.00		
400 V _{AC} Rated Torque (speed) ①②⑦		T _{rtd}	Nm	-	-	-	5.0	4.98	8.5	8.4	
			lb-in	-	-	-	44.3	44.1	75	74	
Rated Speed		N _{rtd}	rpm	-		-		3000		3000	
Rated Power (speed) ①②⑦		P _{rtd}	kW	-	-	-	1.57	1.56	2.67	2.64	
			Hp	-	-	-	2.11	2.09	3.58	3.54	
480 V _{AC} Rated Torque (speed) ①②⑦		T _{rtd}	Nm	-	-	-	4.94	4.90	8.3	8.2	
			lb-in	-	-	-	43.7	43.4	73	73	
Rated Speed		N _{rtd}	rpm	-		-		3000		3000	
Rated Power (speed) ①②⑦		P _{rtd}	kW	-	-	-	1.55	1.54	2.61	2.58	
			Hp	-	-	-	2.08	2.07	3.50	3.46	

Notes:

- ① Motor winding temperature rise, $\Delta T = 100$ °C, at 40 °C ambient.
- ② All data referenced to sinusoidal commutation.
- ③ Add brake inertia if applicable for total inertia.
- ④ Motor with standard heat sink.
- ⑤ May be limited at some values of V_{bus}.
- ⑥ Measured at 25 °C.
- ⑦ For motors with optional shaft seal, reduce torque shown by 0.13 Nm, and increase T_r by the same amount.
- ⑧ Brake option increases weight by 1.2 kg (2.64 lb).

KEM-xV150/KEM-xV250 (1500W/2500W) Motor Parameters

KEM-xV150/KEM-xV250 – 108 mm Flange Series				KEM-2V-	KEM-4V-	KEM-2V-	KEM-4V-
Parameters	Tol	Symbol	Units	150		250	
Torque Constant ①	±10%	K _t	Nm/A _{rms}	0.75	1.27	0.94	1.49
			lb-in/A _{rms}	6.6	11.2	8.3	13.2
Back EMF Constant ②	±10%	K _e	V _{rms} /krpm	48.5	82	61	97
Motor Constant	Nom	K _m	N-m/√W	0.59	0.92	0.58	0.93
			lb-in/√W	5.3	8.2	5.1	8.2
Resistance (line-line) ③	±10%	R _m	ohm	1.06	3.19	0.69	1.72
Inductance (line-line)		L	mH	5.4	15.5	4.0	10.0
Inertia (includes SFD-M feedback) ③	±10%	J _m	kg-cm ²	4.10		7.8	
			lb-in-s ²	3.6E-05		6.9E-03	
Optional Brake Inertia (additional)	±10%	J _m	kg-cm ²	0.200			
			lb-in-s ²	1.8E-04			
Weight (w/o brake) ④		W	kg	4.40		6.4	
			lb	9.7		14.1	
Static Friction ①⑦		T _f	Nm	0.065		0.078	
			lb-in	0.58		0.69	
Viscous Damping ①		K _{dv}	Nm/krpm	0.023		0.033	
			lb-in/krpm	0.204		0.292	
Thermal Time Constant		TCT	minutes	14		19	
Thermal Resistance		R _{thw-a}	°C/W	0.69		0.57	
Pole Pairs				5			
Heat Sink Size ④				12"x12"x0.5" Aluminum Plate			

Notes:

- ① Motor winding temperature rise, ΔT = 100 °C, at 40 °C ambient.
- ② All data referenced to sinusoidal commutation.
- ③ Add brake inertia if applicable for total inertia.
- ④ Motor with standard heat sink.
- ⑤ May be limited at some values of V_{bus}.
- ⑥ Measured at 25 °C.
- ⑦ For motors with optional shaft seal, reduce torque shown by 0.13 Nm, and increase T_f by the same amount.
- ⑧ Brake option increases weight by 1.2 kg (2.64 lb).

Essentials Motor Specifications

KEM-xV300/KEM-4V400 (3000W/4000W) Performance Data – Up to 480 V_{AC} (640 V_{DC} Bus)

KEM-xV300/KEM-4V400 – 138 mm Flange Series

Parameters				KEM-2V-		KEM-4V-			
				300		300		400	
Parameters	Tol	Symbol	Units	No Brake	w/ Brake	No Brake	w/ Brake	No Brake	w/ Brake
Max Rated Voltage	Max	-	V _{AC}	240		480		480	
Continuous Torque for ΔT winding = 100 °C ①②⑦	Nom	T _{CS}	Nm	11.5	11.4	11.8	11.7	17.4	17.2
			lb-in	102	101	104	104	154	152
Continuous Current for ΔT winding = 100 °C ①②⑦	Nom	I _{CS}	A _{RMS}	12.0	11.9	7.4	7.3	11.5	11.4
Continuous Torque for ΔT winding = 60 °C ②⑦	Nom	T _{CS}	Nm	9.2	9.1	9.4	9.4	13.9	13.8
			lb-in	81	81	83	83	123	122
Max Mechanical Speed ⑤	Nom	N _{max}	rpm	4000		4000		4000	
Peak Torque ①②	Nom	T _p	Nm	26.8		27.3		40.5	
			lb-in	237		242		358	
Peak Current	Nom	I _p	A _{RMS}	30.0		18.5		28.9	
Rated Torque (speed) ①②⑦		T _{rtd}	Nm	11.1	11.0	11.6	11.5	16.9	16.6
			lb-in	98	97	103	102	150	147
Rated Speed		N _{rtd}	rpm	1000		500		800	
Rated Power (speed) ①②⑦		P _{rtd}	W	1.16	1.15	0.61	0.60	1.42	1.39
			Hp	1.56	1.54	0.82	0.80	1.90	1.86
Rated Torque (speed) ①②⑦		T _{rtd}	Nm	9.6	9.5	11.1	11.0	15.7	15.4
			lb-in	85	84	98	97	139	136
Rated Speed		N _{rtd}	rpm	3000		1500		1800	
Rated Power (speed) ①②⑦		P _{rtd}	kW	3.02	2.98	1.74	1.73	2.96	2.9
			Hp	4.05	4.00	2.33	2.32	3.97	3.89
Rated Torque (speed) ①②⑦		T _{rtd}	Nm	-	-	9.8	9.7	13.5	13.2
			lb-in	-	-	87	86	119	117
Rated Speed		N _{rtd}	rpm	-		3000		3000	
Rated Power (speed) ①②⑦		P _{rtd}	kW	-	-	3.08	3.05	4.24	4.15
			Hp	-	-	4.13	4.09	5.69	5.57
Rated Torque (speed) ①②⑦		T _{rtd}	Nm	-	-	9.7	9.5	13.1	12.8
			lb-in	-	-	86	84	116	113
Rated Speed		N _{rtd}	rpm	-		3000		3000	
Rated Power (speed) ①②⑦		P _{rtd}	kW	-	-	3.05	2.98	4.12	4.02
			Hp	-	-	4.09	4.00	5.53	5.39

Notes:

- ① Motor winding temperature rise, ΔT = 100 °C, at 40 °C ambient.
- ② All data referenced to sinusoidal commutation.
- ③ Add brake inertia if applicable for total inertia.
- ④ Motor with standard heat sink.
- ⑤ May be limited at some values of V_{bus}.
- ⑥ Measured at 25 °C.
- ⑦ For motors with optional shaft seal, reduce torque shown by 0.25 Nm, and increase T_p by the same amount.
- ⑧ Brake option increases weight by 2.2 kg (4.84 lb).

KEM-xV300/KEM-4V400 (3000W/4000W) Motor Parameters

KEM-xV300/KEM-4V400 – 138 mm Flange Series				KEM-2V-	KEM-4V-	KEM-4V-
Parameters	Tol	Symbol	Units	300	400	400
Torque Constant ①	±10%	K _t	Nm/A _{rms}	0.97	1.61	1.52
			lb-in/A _{rms}	8.6	14.2	13.5
Back EMF Constant ②	±10%	K _e	V _{rms} /krpm	63	104	99
Motor Constant	Nom	K _m	N-m/√W	1.02	1.04	1.35
			lb-in/√W	9.0	9.2	11.9
Resistance (line-line) ③	±10%	R _m	ohm	0.61	1.59	0.85
Inductance (line-line)		L	mH	3.39	9.40	5.40
Inertia (includes SFD-M feedback) ③	±10%	J _m	kg-cm ²	15.8		22.9
			lb-in-s ²	1.4E-02		2.0E-02
Optional Brake Inertia (additional)	±10%	J _m	kg-cm ²	1.0		
			lb-in-s ²	8.9E-04		
Weight (w/o brake) ④		W	kg	6.5		10.1
			lb	14.3		22.3
Static Friction ①⑦		T _f	Nm	0.120		0.180
			lb-in	1.06		1.59
Viscous Damping ①		K _{dv}	Nm/krpm	0.050		0.075
			lb-in/krpm	0.443		0.664
Thermal Time Constant		TCT	minutes	16		18
Thermal Resistance		R _{thw-a}	°C/W	0.53		0.41
Pole Pairs				5		
Heat Sink Size ④				18"x18"x0.5" Aluminum Plate		

Notes:

- ① Motor winding temperature rise, ΔT = 100 °C, at 40 °C ambient.
- ② All data referenced to sinusoidal commutation.
- ③ Add brake inertia if applicable for total inertia.
- ④ Motor with standard heat sink.
- ⑤ May be limited at some values of V_{bus}.
- ⑥ Measured at 25 °C.
- ⑦ For motors with optional shaft seal, reduce torque shown by 0.25 Nm, and increase T_f by the same amount.
- ⑧ Brake option increases weight by 2.2 kg (4.84 lb).

Essentials Motor Specifications

Essentials Motor Performance Curves

KEM-2V020/KEM-xV040 Performance Curves

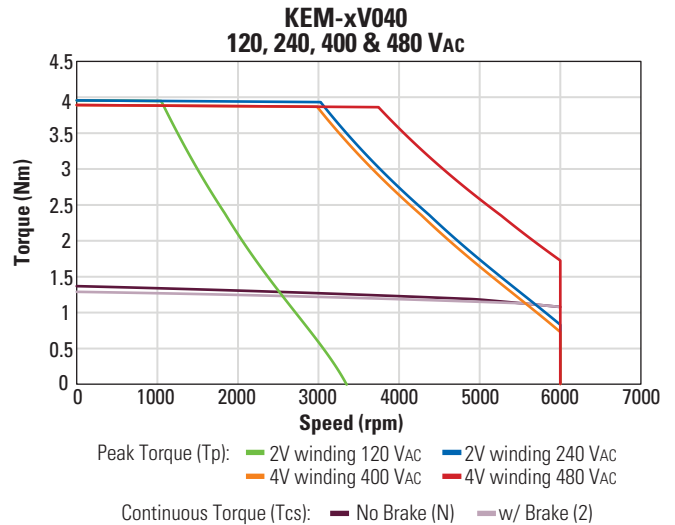
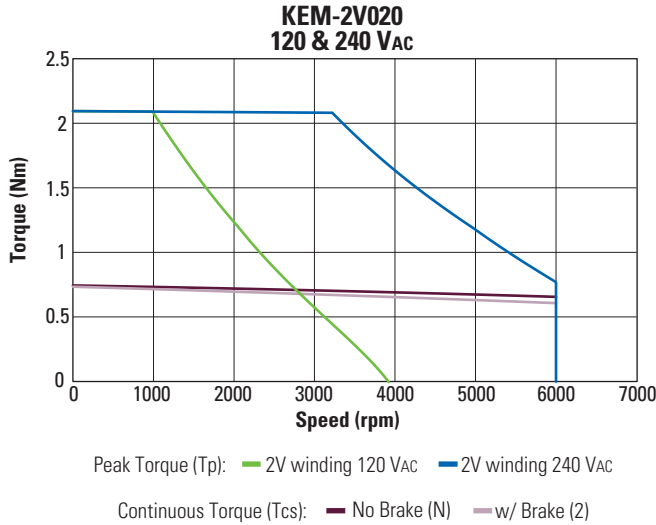

KEM-xV075/KEM-xV100 Performance Curves

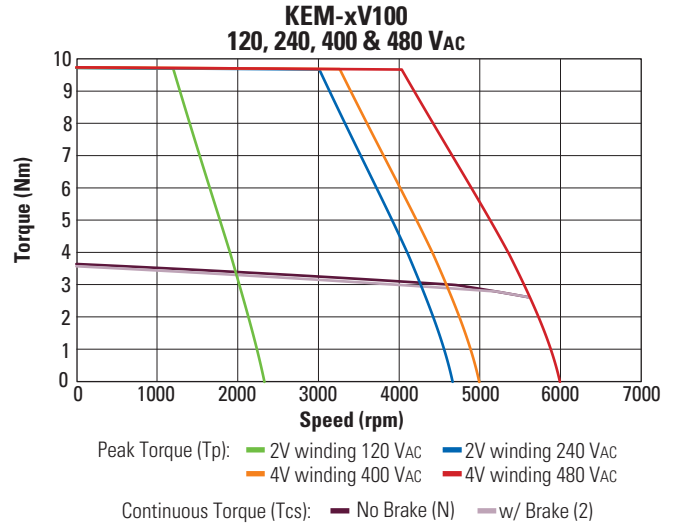
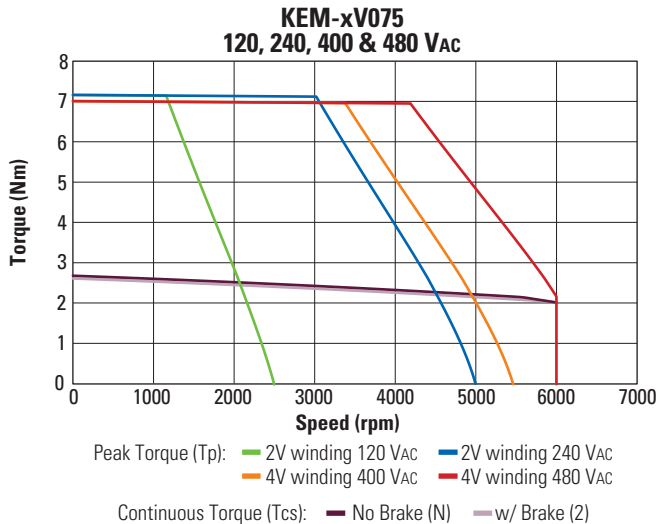

NOTE

The on-line Performance Curve Generator tool provides the most accurate information for specific models and is located at <https://www.kollmorgen.com/en-us/service-and-support/technical/performance-curve-generator>.

Essentials Motor Performance Curves (Continued)

KEM-xV150/KEM-xV250 Performance Curves

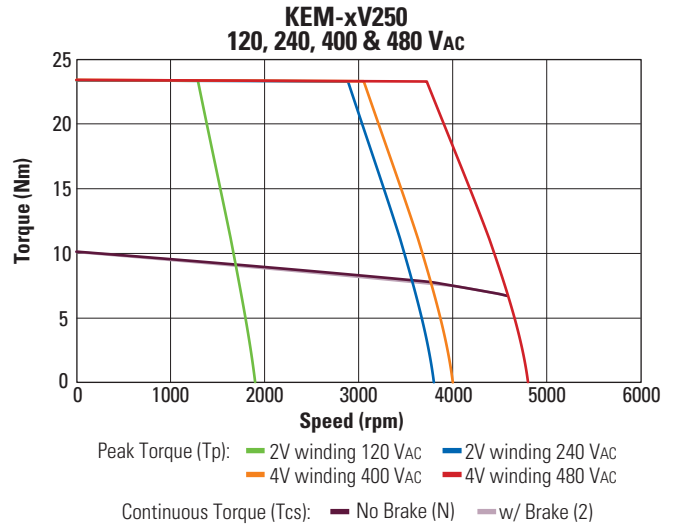
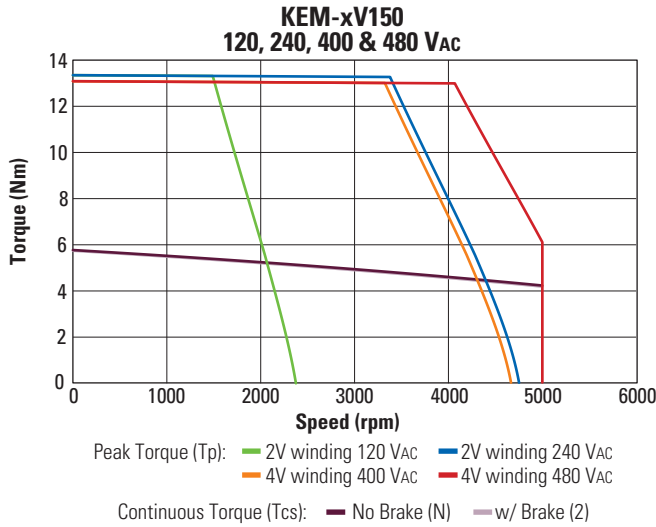

KEM-xV300/KEM-4V400 Performance Curves

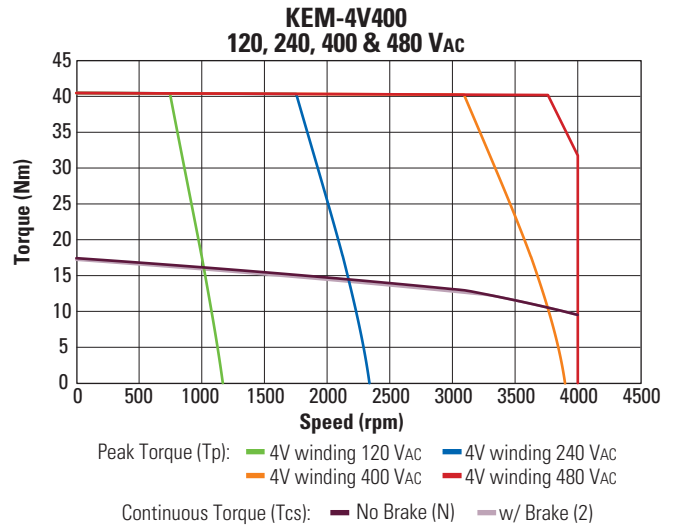
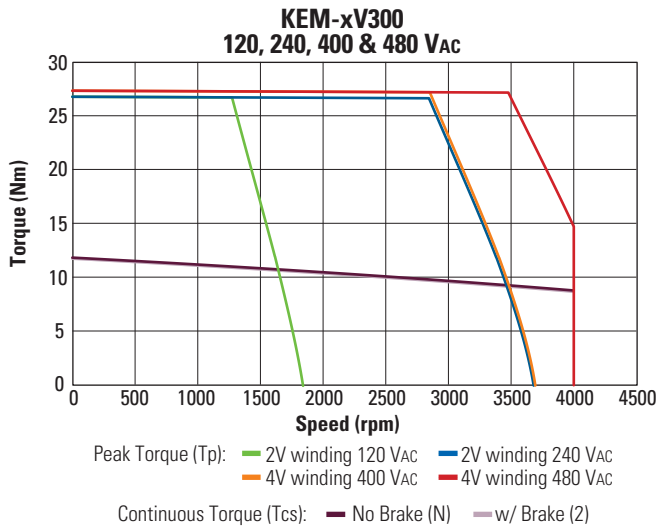

NOTE

The on-line Performance Curve Generator tool provides the most accurate information for specific models and is located at <https://www.kollmorgen.com/en-us/service-and-support/technical/performance-curve-generator>.

Essentials Motor Specifications

KEM-2V020/KEM-xV040 Dimensional Drawings and Data

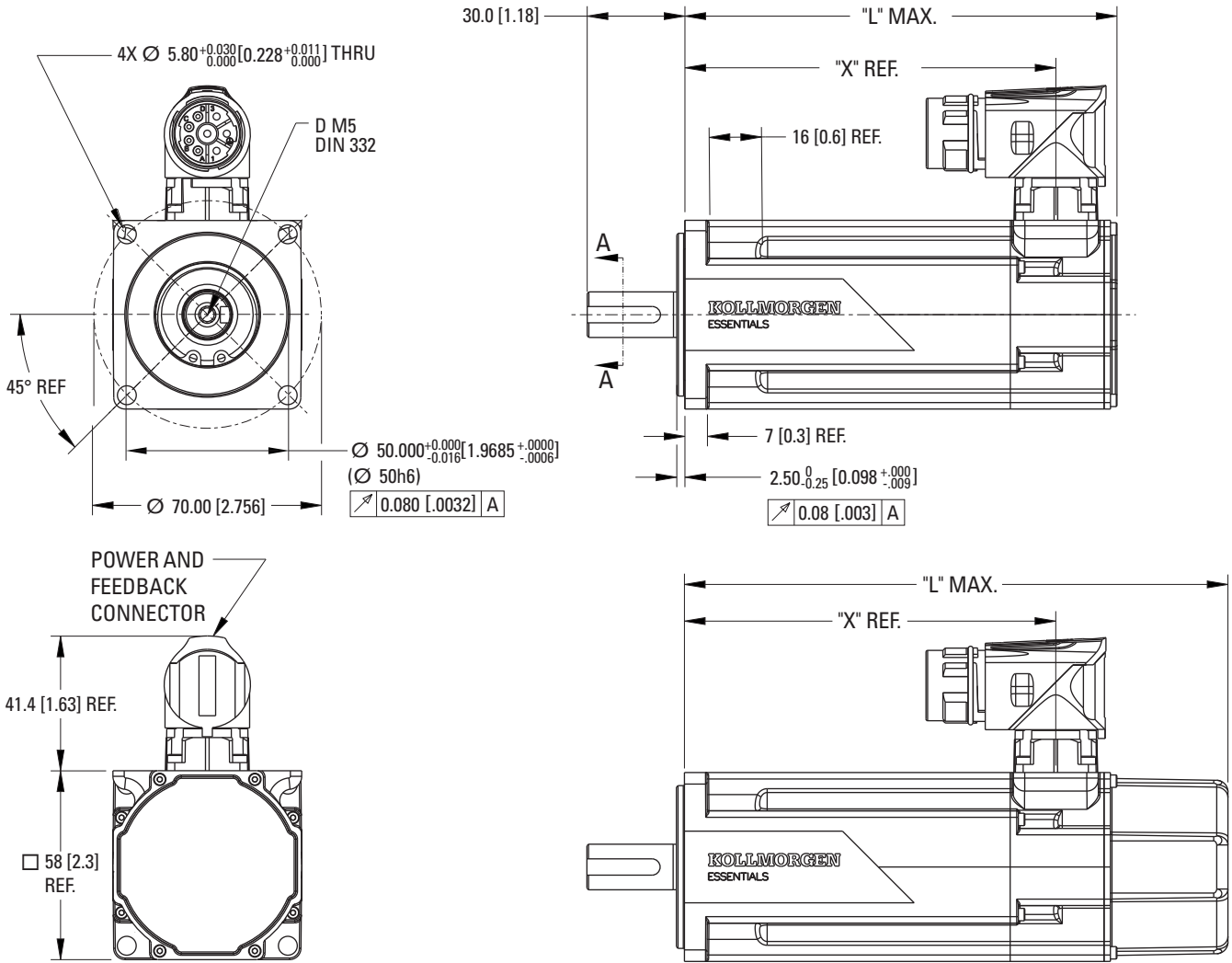

Shaft Key Dimensions

NOTE:
EACH MOTOR PACKAGE CONTAINS
1X MODIFIED KEY - RECTANGULAR METRIC (5.00 X 2.95 X 20.00)
1X STANDARD KEY - RECTANGULAR METRIC (5.00 X 5.00 X 20.00)

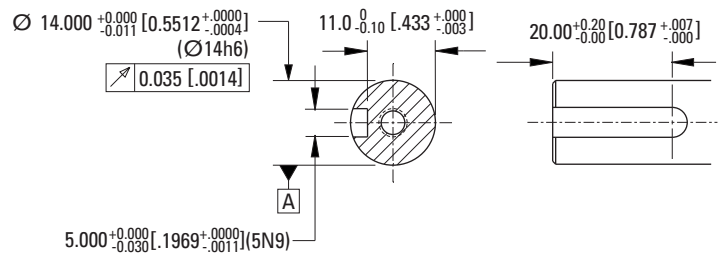
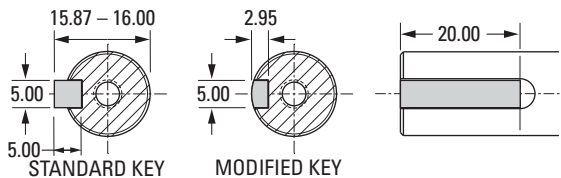

"L" and "X" Dimensional Data

Model	"X" REF.	"L" MAX.	
		No Brake	Brake
KEM-2V020	85.60 [3.370]	104.90 [4.130]	139.00 [5.472]
KEM-xV040	114.10 [4.492]	133.40 [5.252]	167.50 [6.594]

Dimensions in mm [inches]

KEM-xV075/KEM-xV100 Dimensional Drawings and Data

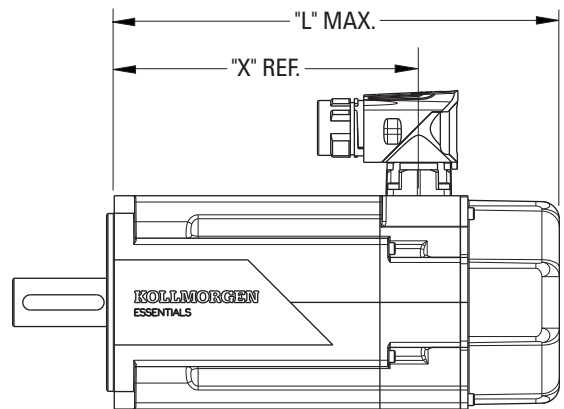
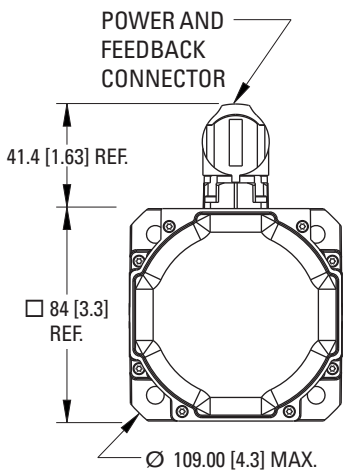
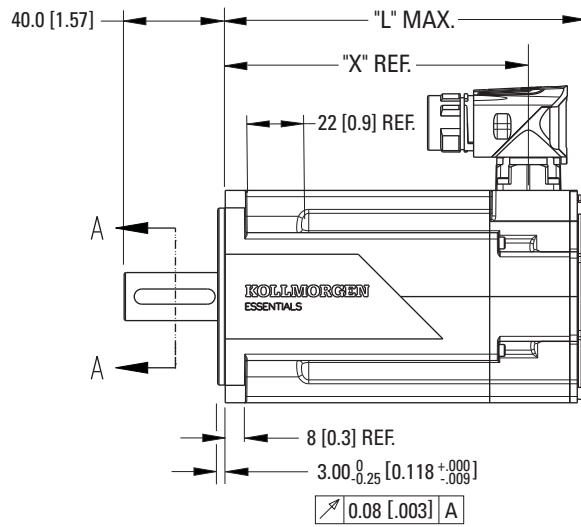
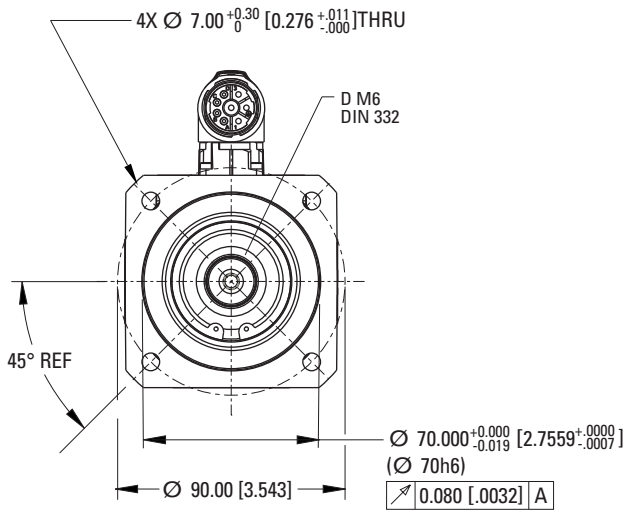

Shaft Key Dimensions

NOTE:
EACH MOTOR PACKAGE CONTAINS
1X MODIFIED KEY - ROUND METRIC (6.00 X 3.47 X 32.00)
1X STANDARD KEY - ROUND METRIC (6.00 X 6.00 X 32.00)

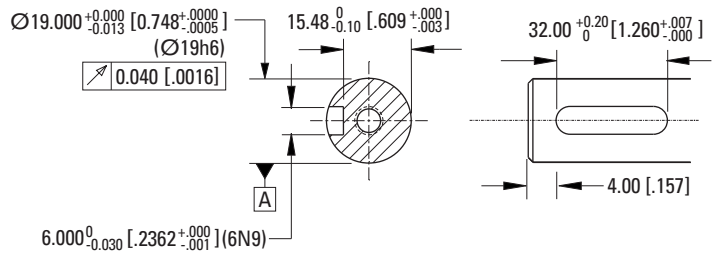
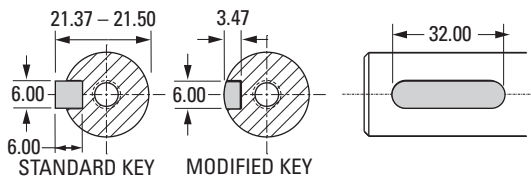

"L" and "X" Dimensional Data

Model	"X" REF.	No Brake	Brake
		"L" MAX.	"L" MAX.
KEM-xV075	102.40 [4.031]	124.80 [4.913]	158.30 [6.232]
KEM-xV100	119.90 [4.720]	142.30 [5.602]	175.80 [6.921]

Dimensions in mm [inches]

Essentials Motor Dimensional Drawings

KEM-xV150/KEM-xV250 Dimensional Drawings and Data

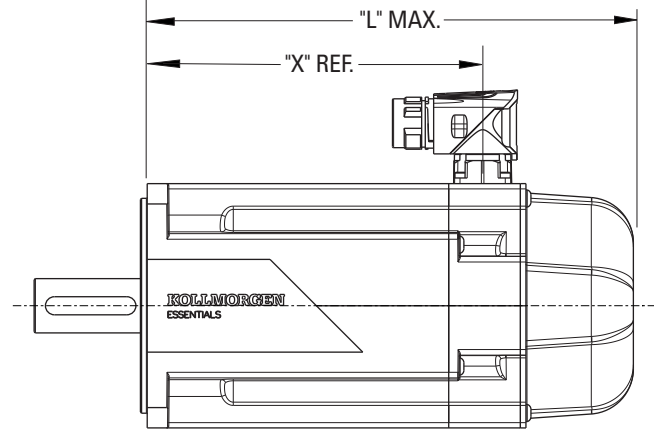
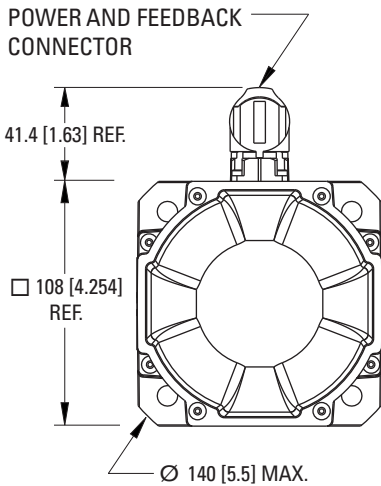
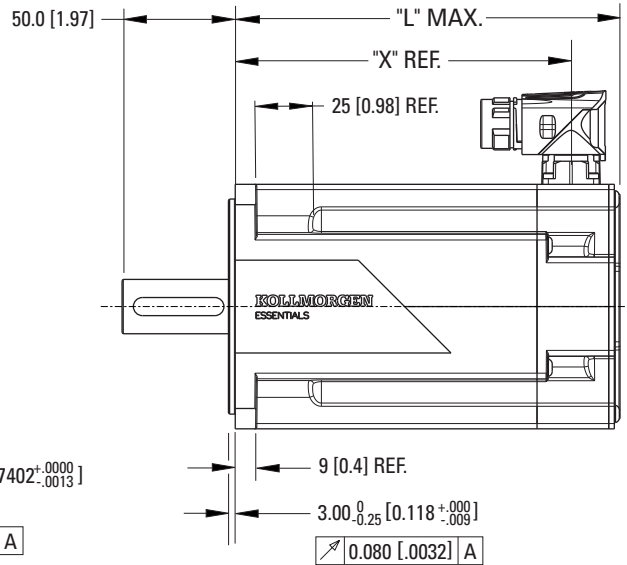
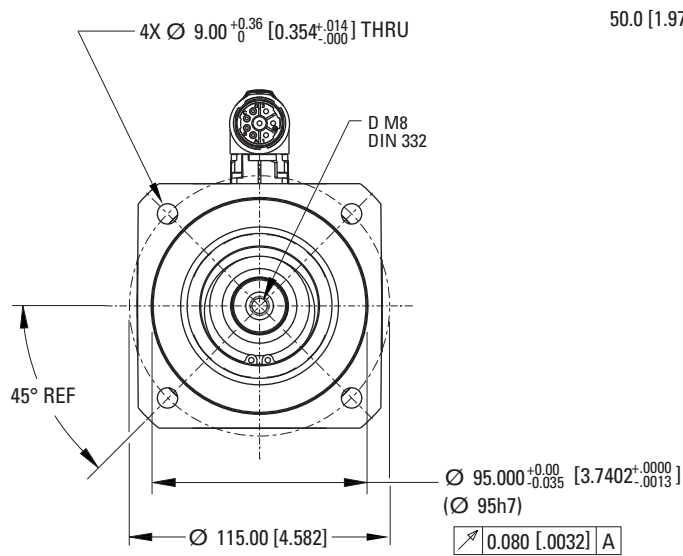

Shaft Key Dimensions

NOTE:
EACH MOTOR PACKAGE CONTAINS
1X MODIFIED KEY - ROUND METRIC (8.00 X 3.95 X 40.00)
1X STANDARD KEY - ROUND METRIC (8.00 X 7.00 X 40.00)

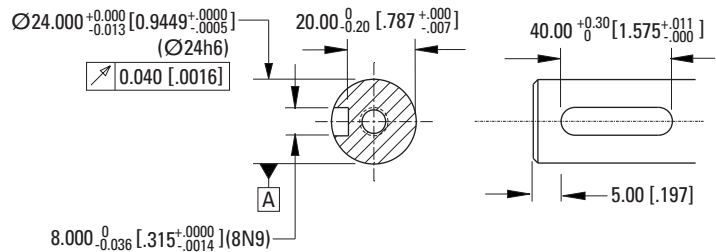
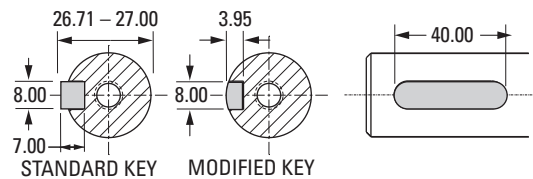

"L" and "X" Dimensional Data

Model	"X" REF.	No Brake	Brake
		"L" MAX.	"L" MAX.
KEM-xV150	111.30 [4.382]	133.50 [5.256]	178.50 [7.027]
KEM-xV250	148.30 [5.838]	170.50 [6.713]	215.50 [8.484]

Dimensions in mm [inches]

KEM-xV300/KEM-4V400 Dimensional Drawings and Data

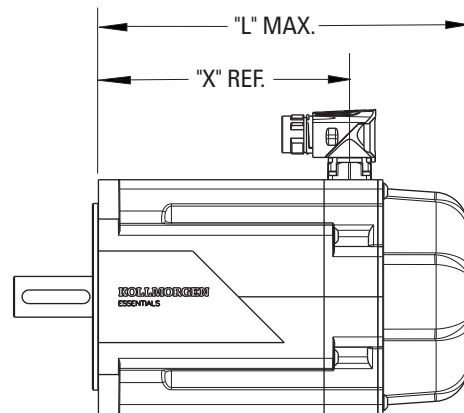
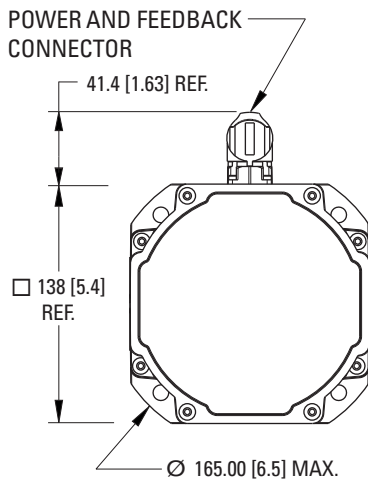
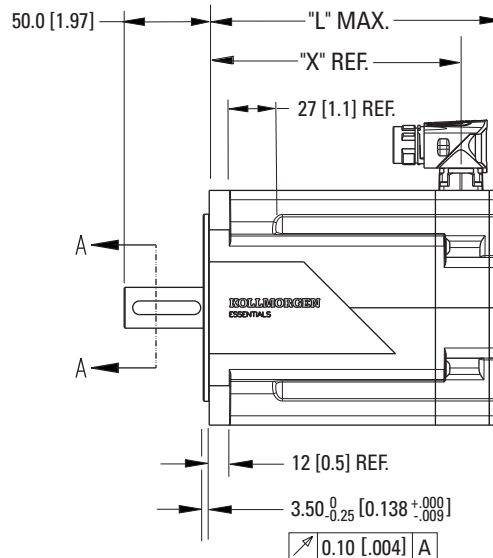
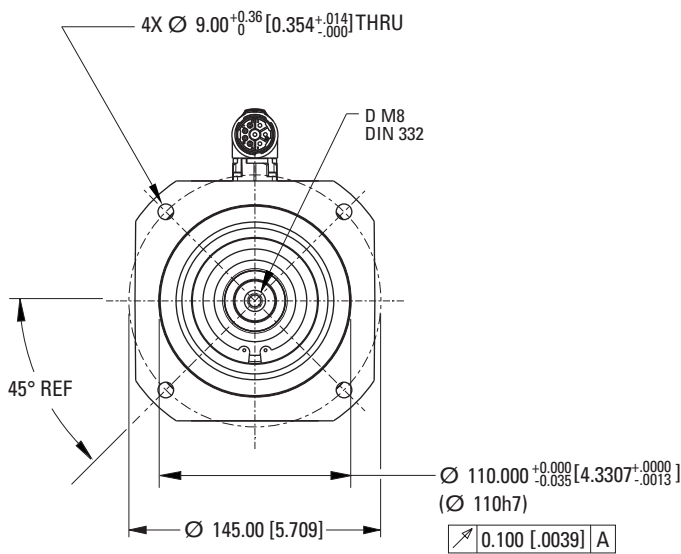

Shaft Key Dimensions

NOTE:
 EACH MOTOR PACKAGE CONTAINS
 1X MODIFIED KEY - ROUND METRIC (8.00 X 3.95 X 40.00)
 1X STANDARD KEY - ROUND METRIC (8.00 X 7.00 X 40.00)

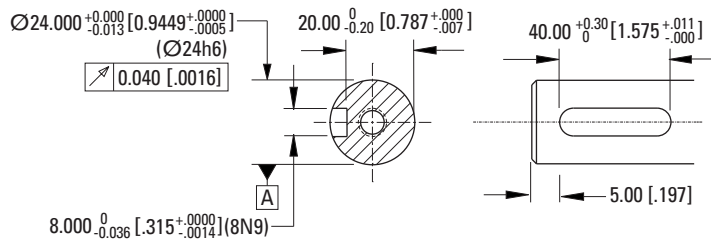
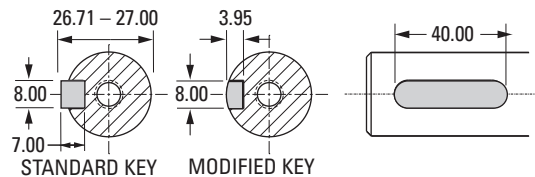

"L" and "X" Dimensional Data

Model	"X" REF.	No Brake		Brake	
		"L" MAX.	"L" MAX.	"L" MAX.	"L" MAX.
KEM-xV300	125.50 [4.941]	148.70 [5.854]	148.70 [5.854]	195.70 [7.705]	195.70 [7.705]
KEM-4V400	148.00 [5.827]	171.20 [7.740]	171.20 [7.740]	218.20 [8.591]	218.20 [8.591]

Dimensions in mm [inches]

Essentials Motor Connector Pinout

Essentials Motor Connector Pinout

9- Connector Pinout – Hybrid combined power and SFD-M feedback

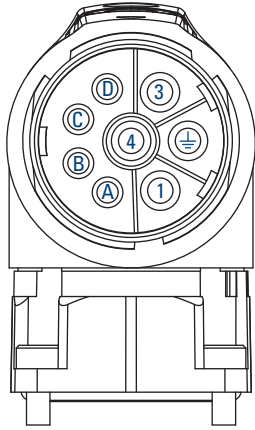

Power + SFD-M

Power + SFD-M

Pin	Function
1	U
PE	PE
3	W
4	V
A	Brake +
B	Brake -
C	SFD-M -
D	SFD-M +

Connector Part Number:
BEDC-110-NN-00-00-1116-000

Mating Connector Part Number:
BSTA-078-NN-00-42-0100-000

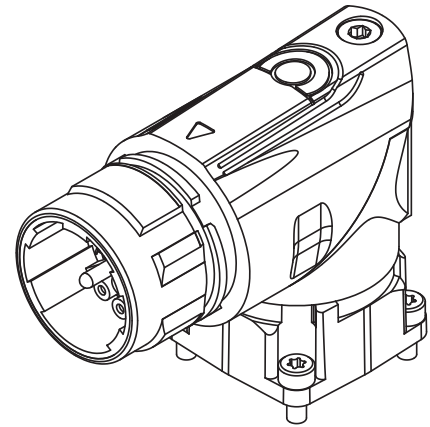

9- Connector

Brake Option

Failsafe, Holding Brake

The holding brake is designed to provide static holding torque to the motor shaft with the brake coil de-energized. The brake must first be released (coil energized) prior to commanding motor rotation as determined by its drop-out time. The brake is intended for holding or “parking” of a stationary motor. It is not intended for dynamic braking. There should be absolutely no motion of the rotor when power is removed from the brake coil.

Essentials Motor Brake Specifications

Motor Family	Holding Torque @20 °C	Operating Voltage	Power Consumption @24 V, 20 °C	Current @24 V, 20 °C	Inertia	Release Delay Time	Application Delay Time
	Nm	V _{DC} ±10%	Watts ±7%	A _{DC}	kg-cm ²	msec	msec
KEM-2V020/KEM-xV040	1.42	24	8.41	0.35	0.013	45	36
KEM-xV075/KEM-xV100	5.3		12.74	0.53	0.058	75	40
KEM-xV150/KEM-xV250	14.5		19.73	0.82	0.166	115	45
KEM-xV300/KEM-4V400	25		25.70	1.07	0.668	155	55

Notes:

- Contamination of the motor internal compartment by oil or other foreign materials will result in failure of the brake. Check the suitability of motor sealing for the working environment.
- Maximal allowed brake backlash is 1.01° (400 W), 0.81° (1000 W), 0.71° (2000 W), 0.51° (4000 W).
- Brake Operating Temperature Range: -20 °C to 120 °C. Sub-zero temperatures present a freezing risk for condensation which could prevent correct brake operation.

Essentials SFD-M Feedback

Kollmorgen Essentials Drive Feedback Option Specifications

Feedback Unit Options

Code	Description	Single-turn or Multi-turn	Feedback Type/Size	Feedback Resolution			
				Device Resolution (Sin/Cos per Rev., Bits or Lines/Rev.)	Essentials Drive Internal Resolution	# of Absolute revs.	Accuracy* (arc-sec)
CB	SFD-M Smart Feedback Device Multi-turn	Multi-turn	15	24-Bits	24-Bits	65,536	±60"

* Accuracy refers to overall system accuracy once installed in the motor. Noise refers to the RMS position noise when at stand-still.

Kollmorgen Smart Feedback Device, Multi-turn (SFD-M) (CB)

The SFD-M Feedback uses a single motor cable, requiring just one cable between the drive and motor.

The feedback has both power and communication on a single wire pair, reducing overall wiring costs. SFD-M offers 24-bit absolute single-turn resolution, batteryless 16-bit (65,536) multi-turn absolute revolutions and an absolute angular accuracy of +/- 1 arc-min.

In addition, the device includes onboard memory for an electronic motor datasheet which enables device auto-recognition for faster setup and commissioning when paired with any Kollmorgen Essentials, AKD, or AKD2G drive.

Angle Measurement:

Single-Turn Resolution: $2^{24} = 16,777,216$ counts per rev

Multi-Turn Absolute Range: $2^{16} = 65,536$ absolute revolutions* (batteryless)

Accuracy: < +/- 1 arc-min typical 25 °C
< +/- 3 arc-min worst case

Electrical Noise: < 2^{-22} Rev rms at full bandwidth

Bandwidth: > 2 kHz at -3 dB

> 1 kHz at -45° phase lag

Max Continuous Speed: 10,000 RPM

Velocity Ripple: < 1% p-p (typical)

Velocity Noise: < 0.3 RPM rms at full bandwidth

Power Supply:

Input Voltage: 7 V - 12 V accepted (at motor terminals)

Input current maximum: 140 mA DC

Digital Communications:

Baud rate: 2.5 Mbaud

Signaling: RS-485 differential using differential Manchester encoding

Update period: New position sample every 51.2 μs

Error detection: 5-bit CRC and running parity check

Environmental:

Feedback Operating Temperature: -40 to 120 °C

Humidity: 10% to 90% non-condensing

Vibration Resistance: 30g (294 m/s²) @ 55-2000 Hz (EN60068-2-6)

Shock Resistance: 100g (981 m/s²) @ 6 ms (EN60068-2-27)

* When paired with AKD, this is limited to 4096 absolute revolutions (12-bits)

Essentials Technical Guide

I. L10 Bearing Fatigue

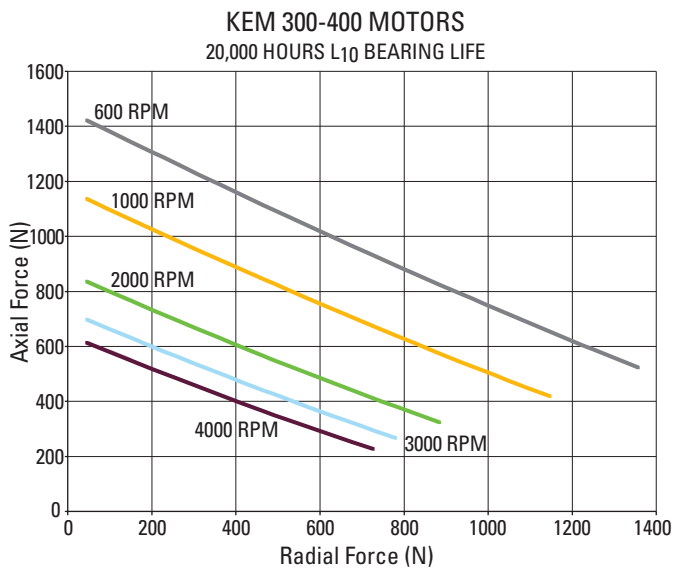
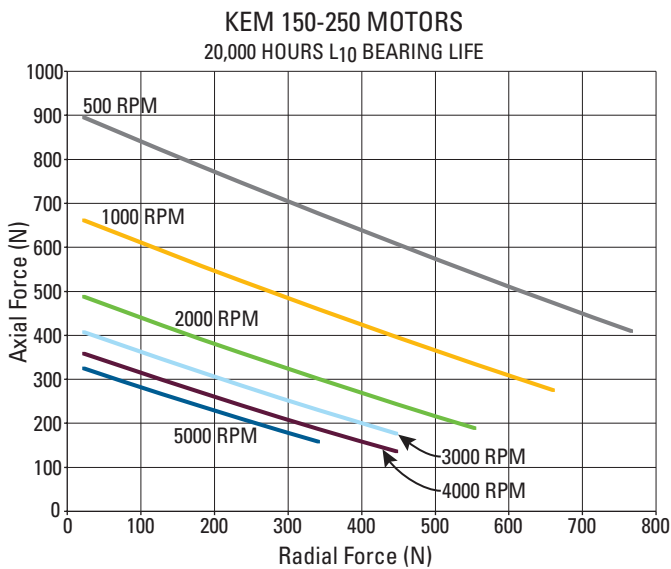
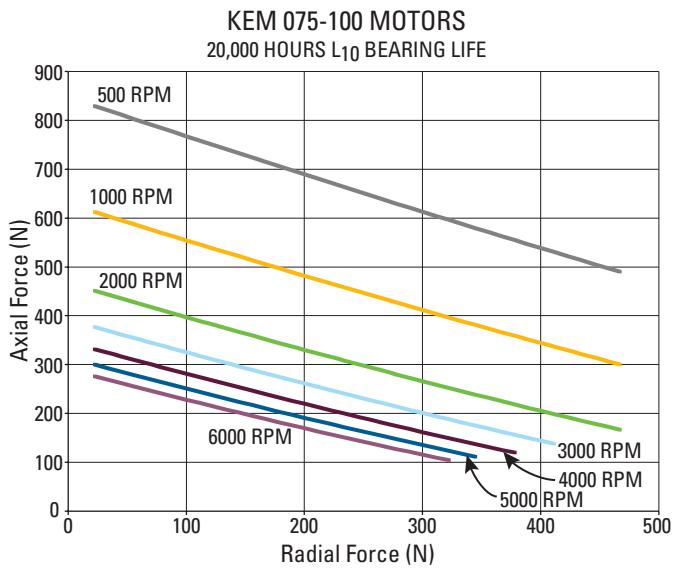
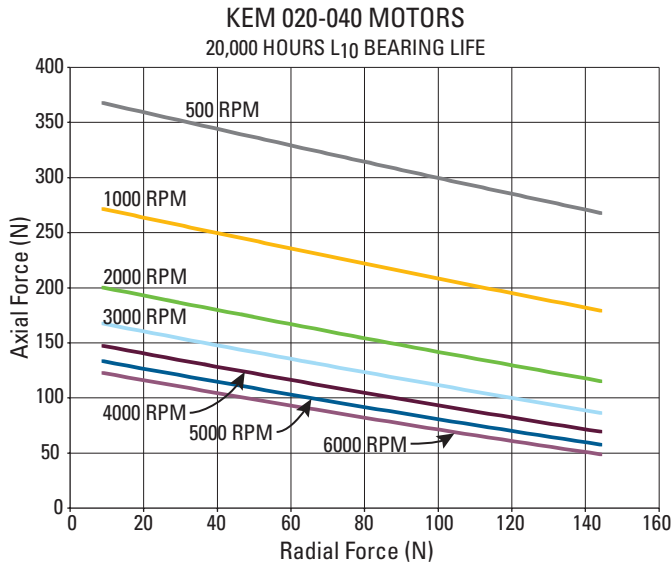

II. Shaft Loading

Motor	Max. Radial Force (N)	Max. Axial Force (N)
KEM-2V020/xV040	150	600
KEM-xV075/xV100	500	1400
KEM-xV150/xV250	830	1740
KEM-xV300/4V400	1940	2200

The maximum radial load ratings reflect the following assumptions:

1. Motors are operated with peak torque of the longest member of the frame size.
2. Fully reversed load applied to the end of the smallest diameter standard mounting shaft extension.
3. Infinite life with 99% reliability.
4. Safety factor = 2.

III. Essentials Motor Thermal Sensor Protective Device

The standard version of each motor is fitted with an electrically isolated PTC Avalanche-Type thermal sensor. The thermal sensors do not provide any protection against short, heavy overloading.

With digital SFD-M (CB) feedback systems, the temperature sensor status is transmitted digitally and evaluated in the drive. Provided that our configured feedback cables are used, the sensor is integrated into the monitoring system of the digital servo amplifiers.

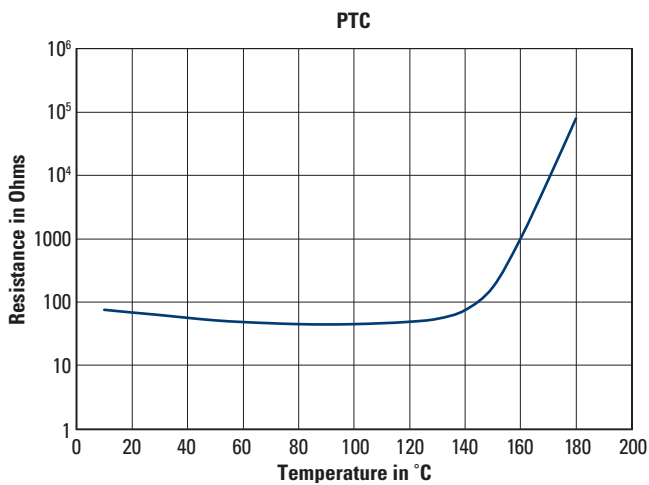

Note:

PTC thermistor (155°C ± 5°C switching temperature) installed.
Resistance at 25°C: ≤550 ohms.
Switching Resistance: ≥1330 ohms within ±5°C of switch temperature.

IV. Motor Phasing Diagram

When the motor is rotated clockwise (CW) as viewed from front shaft end, the following BEMF voltage waveforms result:

- » Voltage phase-UV leads Voltage phase-VW by 120-degrees
- » Voltage phase-VW leads Voltage phase-WU by 120-degrees
- » Voltage phase-WU leads Voltage phase-UV by 120-degrees

BEMF Waveforms

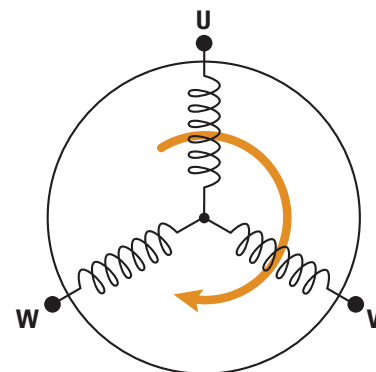
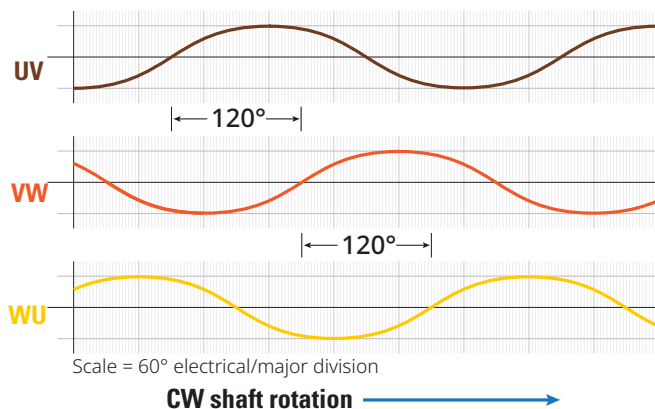

Essentials System Cables

High-performance servo systems require high signal integrity. Electrical noise in the system can cause degraded performance or even instability. Therefore, well-designed connectors and cables are as critical to the system as are motors, drives and controls. A system is only as good as its weakest link. Kollmorgen guarantees the performance and quality of its servo systems only when you use Kollmorgen-supplied motors, drives and cables. Not all cables are created equal.

The Kollmorgen Essentials Cable not only works with Essentials Motors, but will also work with Kollmorgen AKM and AKM2G motors configured with a "9" connector option for AKM or "A" connector option for AKM2G and SFD-M or SFD-3 feedback.



Essentials Drive Connectors to SpeedTec M23 Connector
8-Lead Cable (3 Power + GND + 2 COM + 2 Brake)

Essentials Cable Physical Properties

Bend Radius and Weight Specifications

Cable Type	Jacket Material	Main Conductor Size [mm ²]	OD [mm]	Bend Radius (min.)		Cable Weight	
				Static [mm]	Dynamic [mm]	Assembled Weight of 1 Meter Cable [kg]	Weight Adder per Meter [kg/m]
H2	PUR	1.5	13.2	66	92.4	0.40	0.20
		2.5	14.2	71	99.4	0.55	0.25

Note: Essentials Cables are rated for 80 °C and 1000 Vac

Life Cycle – Lifetime at Specified Conditions

Cable Type	Cycles @ Bend Radius [F x DIA]	Temp from/to [°C]
H2	12E+06	-40/+90

Characteristic Impedance

10 MHz: 110 ± 10 Ohm -
(2 x AWG22)ST/SN (BUS)

Certifications/Standards

CE Oil Resistance
CEI 20-35 Flame Resistance
Lead-free Silicone-Free
Clean room UL/ULC
NFPA 79

Kollmorgen Essentials Cable Nomenclature



H2 - 51 - 015 - A5 - 00 - xxxx00

Cable Version

H2 Mid-flex Hybrid PUR with brake

Connector Type

51 KED-SPM-6V03S, KED-SPM-6V06S
52 KED-SPM-6V12S, KED-SPM-7VxxS

Cable Type

015 1.5 mm² power conductors
025 2.5 mm² power conductors

Length

xxxx00 Length, mm (max. 25 m)
Stocked Lengths: 1, 3, 6, 9, 12 m
Examples:
6 m cable = 006000, 12 m cable = 012000

Options

00 Standard Option Set

Motor Mating Connector Type

A5 KEM/AKM/AKM2G M23 SpeedTec (8)
W1 AKMA, M23 Hummel (8)
W5 AKMH, M23 Hummel (8)

Kollmorgen Essentials Cable Options

- H2-51-015-YZ-00-xxxx00 for KED-SPM-6V03S, KED-SPM-6V06S
- H2-52-015-YZ-00-xxxx00 for KED-SPM-7V03S, KED-SPM-7V06S
- H2-52-025-YZ-00-xxxx00 for KED-SPM-6V12S, KED-SPM-7V12S

YZ = A5, W1 or W5

Each cable option will have 25 SKUs (xxxx00), from 001000 (1 m) up to 025000 (25 m) in 1 m increments

Essentials System Cable Connector Pinouts

Drive Connector X1: Motor, Power + Brake

Signal	Description
BR-	Motor holding brake
BR+	Motor holding brake
PE	Protective Earth (motor housing)
U	Motor Phase U
V	Motor Phase V
W	Motor Phase W

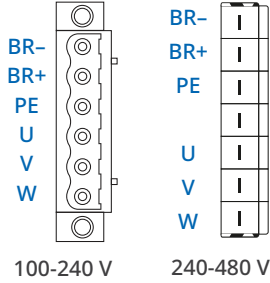

Drive Connector X23: Feedback Pinouts

Pin	SFD-M
1	COM+
2	COM-

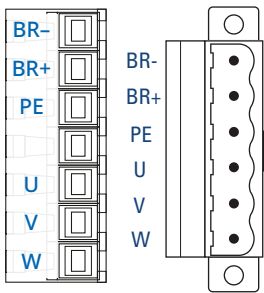
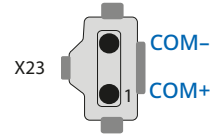

52

51

Essentials Drive Connectors to M23 Motor Connector

H2 - 5x - 0xx - A5

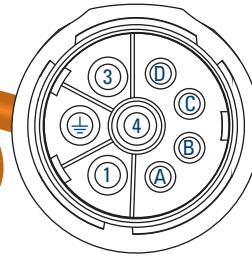

A5, W5

Motor Connector Pinout

A5/W5 Pin	Function	W1 Pin
1	U	U
2	PE	PE
3	W	W
4	V	V
A	Brake +	A
B	Brake -	D
C	SFD-M+	1
D	SFD-M-	2

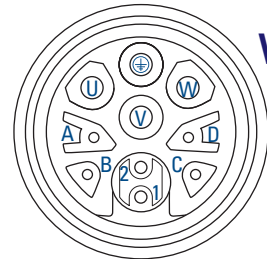

W1



Essentials Accessories

Drive Accessories

Regen Resistors - External IP40

- BAFP(U)-85-33-S 85 W, 33 Ohm, 210 x 60 x 27 mm
For use with 6V03 and 6V06 drives
- BAFP(U)-100-33-S 100 W, 33 Ohm, 239 x 70 x 27 mm
For use with 6V12 and 7Vxx drives

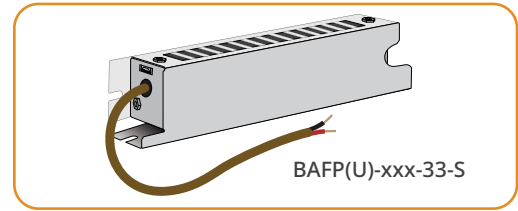

EMC Filters

Drive Model	Filter Order Code			
	≤ 10 m Cable Standard EMC Requirements		> 10 m Cable High EMC Requirements	
	1 phase (6V only)	3 phase (6V/7V)	1 phase (6V only)	3 phase (6V/7V)
6V03/7V03	KED-1MF-06	KED-3MF-10	DE-202203	DE-202205
6V06/7V06	KED-1MF-10		DE-202204	
6V12/7V12	KED-1MF-20	KED-3MF-20	DE-TBD	DE-202206



Mating Connectors

- KED-CONKIT-MV36 Connector kit with X3 and X10 connectors for 6V03S, 6V06S
- KED-CONKIT-MV12 Connector kit with X3 and X10 connectors for 6V12S
- KED-CONKIT-HV36 Connector kit with X3 and X10 connectors for 7V03S, 7V06S
- KED-CONKIT-HV12 Connector kit with X3 and X10 connectors for 7V12S
- KED-CON-X3-MV36 Mating connector X3 (Mains Power) for 6V03S, 6V06S
- KED-CON-X3-MV12 Mating connector X3 (Mains Power) for 6V12S
- KED-CON-X3-HV36 Mating connector X3 (Mains Power) for 7V03S, 7V06S
- KED-CON-X3-HV12 Mating connector X3 (Mains Power) for 7V12S
- KED-CON-X10 Mating connector X10 (24V in and STO)



Shield Clamp

- KED-SHIELD-25
Shield clamp for up to 2.5 mm² cable



Motor Accessories

Shaft Key Kit

KEM-020-040-SKK
KEM-075-100-SKK
KEM-150-400-SKK

Spare shaft key kits for KEM motors. The middle digits represent the motor variations they support. KEM-150-400-SKK is compatible with 1500 W through 4000 W variations.



Shaft Seal Kit

KEM-020-040-SSK
KEM-075-100-SSK
KEM-150-250-SSK
KEM-300-400-SSK

Optional shaft seal kits for KEM motors to achieve full IP65 rating. The middle digits represent the motor variations they support.

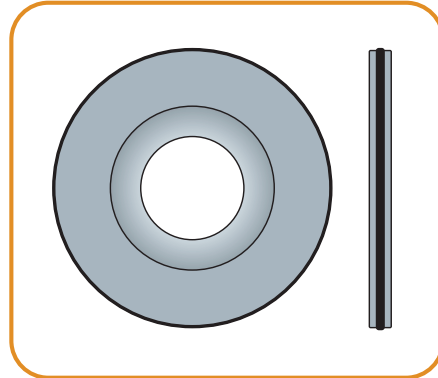

Essentials Accessories

Cable Accessories - Drive-side Connectors for User-customized Cables

These drive-side cable connectors are readily available from electronic component distributors and are not offered by Kollmorgen.

H2-51-015-A5-00-xxxx00 Drive Side Connector:

X1 - 6V03/6V06
Phoenix Contact 1763711



X1 - 6V03/6V06
PE + Motor Ferrules:
Weidmuller 9019120000
(4 pcs)
Brake Ferrules:
Weidmuller 0463000000
(2 pcs)



H2-52-025-A5-00-xxxx00 Drive Side Connector:

X1 - 6V12/7Vxx
Phoenix Contact 1233112



X1 - 6V12/7Vxx
PE + Motor Ferrules:
Weidmuller 9005850000
(4 pcs)
Brake Ferrules:
Weidmuller 0463000000
(2 pcs)



H2-5x-0xx-A5-00-xxxx00 Drive-side X23 Connector:

X23
Amphenol MSPEP2L02A0

Feedback connector installation instructions
can be found on Essentials webpage in the
Manuals tab



NOTICE

Essentials Drive and Motor system compatibility and performance cannot be guaranteed by the use of user-customized or third-party cables.

Motors – Copyrights, Trademarks, and Disclaimers

Copyright 2026 Regal Rexnord Corporation, All Rights Reserved.

Information in this document is subject to change without notice. The software package described in this document is furnished under a license agreement. The software package may be used or copied only in accordance with the terms of the license agreement.

This document is the intellectual property of Kollmorgen and contains proprietary and confidential information. The reproduction, modification, translation or disclosure to third parties of this document (in whole or in part) is strictly prohibited without the prior written permission of Kollmorgen.

Kollmorgen Trademarks

Regal Rexnord and [Kollmorgen](#) are trademarks of [Regal Rexnord Corporation](#) or one of its affiliated companies.

These trademarks or trade names are owned by or under the control of Regal Rexnord Corporation or any of its affiliates:

- | | | | |
|--------------------------------|------------|------------------------------------|----------------------|
| » Kollmorgen Essentials System | » AKM | » Kollmorgen Automation Suite | » PCMM |
| » Kollmorgen Essentials Cable | » AKMA | » KAS | » PCMM2G |
| » Kollmorgen Essentials Drive | » AKME | » Kollmorgen Visualization Builder | » SafeMotion Monitor |
| » Kollmorgen Essentials Motor | » AKMH | » KVB | » SMM |
| » AKD | » BLM | » MKD | » TBM |
| » AKD2G | » DDL | » P8000 | » TBM2G |
| » AKD PDMM | » Goldline | | » WorkBench |

Other Trademarks

Any of these other trademarks and/or trade names may be used and/or identified in Kollmorgen products, firmware, and/or software.

These are believed to be the trademarks and/or trade names of their respective owners and are not owned or controlled by Regal Rexnord Corporation:

- | | |
|--|---|
| » BiSS: iC-Haus GmbH. | » LOCTITE 640: HenkeAG & CO. KGAA. |
| » CANopen: CAN in Automation (CIA). | » LOCTITE: HenkeAG & CO. KGAA. |
| » DRIVE-CLiQ: Siemens Aktiengesellschaft. | » Modbus: Schneider Electric USA, Inc. |
| » EnDat: Dr. Johannes Heidenhain GmbH. | » MOLYKOTE: DDP Specialty Electronic Materials US 9, LLC. |
| » EtherCAT and Safety over EtherCAT: Beckhoff Automation GmbH. | » Mylar: DUPONT Teijin Films U.S. |
| » EtherCAT: Beckhoff Automation GmbH. | » PHOENIX CONTACT: Phoenix Contact GmbH & Co. KG. |
| » EtherNet/IP Communication Stack: RockwellAutomation. | » PROFINET: PROFIBUS Nutzerorganisation e.V. |
| » EtherNet/IP: ODVA, Inc. | » Scotch-Weld 2214: 3M Company. |
| » Ghostscript : Artifex Software, Inc. (distributed under the AGPL license). | » sercos: Sercos InternationaE.V. |
| » HIPERFACE DSL: SICK AG. | » SIMATIC: Siemens Aktiengesellschaft. |
| » HIPERFACE: SICK AG. | » SpeedTec: Liqui-Moly GmbH or TE Connectivity IndustriaGmbH. |
| » Hysol: HysoHuawei Electronics Co.,LTD. | • If SpeedTec is used as a lubricant, it belongs to Liqui-Moly GmbH. |
| » IECEx: InternationaElectrotechnicaCommission (IEC). | • If SpeedTec is used as a connector, it belongs to TE Connectivity IndustriaGmbH |
| » Instapak: Sealed Air Corporation. | » Teflon: The Chemours Company FC, LLC. |
| » INTERCONTEC: INTERCONTEC Pfeiffer Industrie-Steckverbindungen GmbH. | » Windows: Microsoft Corporation. |

Disclaimers

Technical changes which improve the performance of the device may be made without prior notice!

This document is the intellectual property of Kollmorgen. All rights reserved. No part of this work may be reproduced in any form (by photocopying, microfilm or any other method) or stored, processed, copied or distributed by electronic means without the written permission of Kollmorgen.

The information in this document is believed to be accurate and reliable at the time of its release. Kollmorgen assumes no responsibility for any damage or loss resulting from the use of this help, and expressly disclaims any liability or damages for loss of data, loss of use, and property damage of any kind, direct, incidental or consequential, in regard to or arising out of the performance or form of the materials presented herein or in any software programs that accompany this document.

Technische Änderungen, die der Verbesserung der Geräte dienen, vorbehalten!

Dieses Dokument ist geistiges Eigentum von Kollmorgen. Alle Rechte vorbehalten. Kein Teil dieses Werkes darf in irgendeiner Form (Fotokopie, Mikrofilm oder in einem anderen Verfahren) ohne schriftliche Genehmigung von Kollmorgen reproduziert oder unter Verwendung elektronischer Systeme verarbeitet, vervielfältigt oder verbreitet werden.

Die Genauigkeit und Verlässlichkeit der Informationen in diesem Dokument entspricht dem Kenntnisstand zum Zeitpunkt der Veröffentlichung. Kollmorgen übernimmt keine Verantwortung für Schäden oder Verluste, die sich aus der Verwendung dieser Hilfe ergeben, und lehnt ausdrücklich jegliche Haftung sowie Schadensersatzansprüche für Datenverlust, entgangene Nutzung und Sachschäden jeglicher Art ab, inklusive direkter, zufälliger oder Folgeschäden im Zusammenhang mit der Funktion oder Form des hierin oder in einem der mit diesem Dokument gelieferten Software enthaltenen Materials.



Motors – Copyrights, Trademarks, and Disclaimers

Disclaimers (continued)

Es posible que se implementen sin aviso previo cambios técnicos que mejoran el rendimiento del dispositivo.

La propiedad intelectual de este documento pertenece a Kollmorgen. Todos los derechos reservados. Se prohíbe la reproducción de este documento por ningún medio (fotocopia, microfilm u otro método), así como su almacenamiento, procesamiento, copia o distribución por medios electrónicos, sin el consentimiento por escrito de Kollmorgen.

La información incluida en este documento se considera correcta y confiable en el momento de su publicación. Kollmorgen no asume ninguna responsabilidad por ningún daño o pérdida causados por el uso de este documento de ayuda y rechaza explícitamente toda responsabilidad o daño por pérdida de datos, pérdida de uso y daños en la propiedad de cualquier tipo, ya sea directos, incidentales o consecuentes, en relación con el rendimiento o la forma de los materiales aquí publicados, o con los programas de software que acompañan a este documento, o que surjan de estos.

Les modifications techniques qui améliorent les performances du dispositif peuvent être apportées sans avis préalable !

Ce document est la propriété intellectuelle de Kollmorgen. Tous droits réservés. Aucune partie de ce document ne peut être reproduite sous quelque forme que ce soit (photocopie, microfilm ou autre méthode) ni stockée, traitée, copiée ou distribuée de manière électronique sans l'autorisation écrite de Kollmorgen.

Les informations contenues dans ce document sont considérées exactes et fiables au moment de leur publication. Kollmorgen n'assume aucune responsabilité pour tout dommage ou perte résultant de l'utilisation de cette aide, et rejette expressément toute responsabilité ou tous dommages pour la perte de données, la perte d'utilisation et les dommages matériels de toute nature, directs, accessoires ou indirects, en ce qui concerne ou découlant des performances ou de la forme des matériaux présentés ici ou dans tout programme logiciel accompagnant ce document.

Modifiche tecniche volte a migliorare le prestazioni del dispositivo possono essere apportate senza preavviso.

Il presente documento è proprietà intellettuale di Kollmorgen. Tutti i diritti riservati. È vietata la riproduzione di qualsiasi parte di quest'opera in qualsiasi forma (fotocopia, microfilm o qualunque altro metodo) così come la memorizzazione, il trattamento, la copia o la distribuzione tramite mezzi elettronici senza l'autorizzazione scritta di Kollmorgen.

Le informazioni contenute nel presente documento sono ritenute accurate e affidabili al momento della pubblicazione. Kollmorgen non si assume alcuna responsabilità per eventuali danni o perdite risultanti dall'uso di questa guida e declina espressamente qualsiasi responsabilità o danni dovuti a perdita di dati, mancato utilizzo e danni materiali di qualunque tipo, diretti, accidentali o consequenziali, in relazione a o derivanti dal funzionamento o dalla forma dei materiali presentati qui o in eventuali programmi software che accompagnano il presente documento.

デバイス性能の向上のため、予告なく技術的な変更が実装される場合があります。

本書の知的財産権はKollmorgenに帰属しており、無断複写・転載は禁じられています。本書のいずれの部分も、Kollmorgenの書面による許可なしに、いかなる複製(写真、マイクロフィルムまたはその他の手段)、保管、改変、複写または電子的配布を行うことはできません。

本書に記載されている情報は、発行時において正確かつ信頼できるものですが、Kollmorgenはこのヘルプの使用により生じるいかなる損害や損失についても責任を負いません。また、本書の履行、資料形式または付随するあらゆるソフトウェアプログラムに関連して、あるいはこれらが原因で発生する、直接的、偶発的または結果的な、いかなるデータの損失、利用機会の喪失および財産の損害に対しても、一切の責任や損害賠償を明示的に否認します。

기기의 성능을 향상시키는 기술적 변경 사항은 사전 공지 없이 이루어질 수 있습니다

본 문서의 지적 재산권은 Kollmorgen에 있습니다. All rights reserved. 본 저작물의 어떤 부분도 Kollmorgen의 서면 허가 없이 어떠한 형태(사진 복사, 마이크로필름 또는 기타 방법)로도 복제하거나 전자 수단으로 저장, 처리, 복사 또는 배포할 수 없습니다.

본 문서의 정보는 공개 시점을 기준으로 정확하고 신뢰할 수 있는 것으로 간주됩니다. Kollmorgen은 본 도움말의 사용으로 인한 어떠한 피해나 손실에 대해 책임을 지지 않으며, 본 문서 또는 본 문서와 함께 제공되는 소프트웨어 프로그램에 제시된 자료의 성능 또는 형태와 관련하여 또는 그로 인해 직접적, 우발적 또는 결과적으로 발생한 모든 유형의 데이터 손실, 사용 손실, 재산상의 피해에 대한 책임이나 손해를 명시적으로 부인합니다.

Alterações técnicas que melhoram o desempenho do dispositivo podem ser feitas sem aviso prévio!

Este documento é propriedade intelectual da Kollmorgen. Todos os direitos reservados. Nenhuma parte deste trabalho pode ser reproduzida sob qualquer forma (por fotocópia, microfilme ou qualquer outro método) ou armazenada, processada, copiada ou distribuída por meios eletrônicos sem a permissão escrita da Kollmorgen.

Acredita-se que as informações contidas neste documento sejam precisas e confiáveis no momento de sua divulgação. A Kollmorgen não assume nenhuma responsabilidade por quaisquer danos ou perdas resultantes do uso desta ajuda, e se isenta expressamente de qualquer responsabilidade ou danos por perda de dados, perda de uso e danos materiais de qualquer espécie, direta, incidental ou subsequente em relação a ou resultante do desempenho ou da forma dos materiais apresentados aqui ou em quaisquer programas de software que acompanhem este documento.

我们可能会进行技术更改以提高设备性能，恕不另行通知！

本文档知识产权归 Kollmorgen 所有，Kollmorgen 保留所有权利。未经 Kollmorgen 书面许可，不得以任何形式（影印、缩微胶片或其他任何方式）复制本文档任何内容，亦不得以任何电子手段存储、处理、复制或分发本文档的任何内容。

据我们所知，本文档所含信息截至发布日是准确可靠的。对于因使用本帮助文档而导致的任何损害或损失，Kollmorgen 概不承担任何责任。Kollmorgen 特此明确声明，对于因本文档中的任何材料或随附本文档之任何软件程序的性能或形式导致的或与之相关的任何类型的数据丢失、使用中中断损失或财产损害（包括直接、间接和衍生性损失或损害），Kollmorgen 不承担任何法律责任或损害赔偿。

Complete Motion and Automation Solutions

The highest performance and the right fit for any application.



Online Design Tools

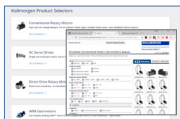

Product Selector
Quickly choose the ideal products for your application needs.



Motioneering
Size your motion system based on application requirements and motion profiles.



Performance Curve Generator
Optimize housed and frameless motor windings based on power and environmental factors.



3D Models
Visualize products in 3D and download CAD files for use in your design.

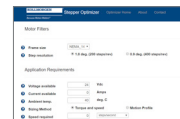

Stepper Optimizer
Interactively choose the most efficient stepper solution for your application.



AKD2G Safe Dynamic Brake Calculator
Specify and size the right braking components while saving development time.



Learn more and try our design tools now.

More Expertise for a More Successful Machine

Our global engineering, service and support network provides deep knowledge of all the major industries that rely on advanced motion control and automation technology. We offer world-class engineering expertise, self-service design tools, personalized field service, and easy access to our design, application and manufacturing centers in strategic locations across the globe.

About Kollmorgen

Kollmorgen, a Regal Rexnord brand, has more than 100 years of motion experience, proven in the industry's highest-performing, most reliable motors, drives, linear actuators, AGV (Automated Guided Vehicle) control solutions, and automation control platforms. We deliver breakthrough solutions that combine exceptional performance, reliability and ease of use, giving machine builders an irrefutable marketplace advantage.

KOLLMORGEN

A REGAL REXNORD BRAND

www.kollmorgen.com

© 2026 Kollmorgen Corporation. All rights reserved
See Copyrights, Trademarks, and Disclaimers for legal ownership.

KM_CA_000444_RevC_EN